



Haas Automation, Inc.

---

# Chucker Lathe

Operator's Manual Supplement  
96-0226  
Revision B  
November 2017  
English  
Original Instructions

---

Haas Automation Inc.  
2800 Sturgis Road  
Oxnard, CA 93030-8933  
U.S.A. | HaasCNC.com



---

© 2017 Haas Automation, Inc.

All rights reserved. No part of this publication may be reproduced, stored in a retrieval system, or transmitted, in any form, or by any means, mechanical, electronic, photocopying, recording, or otherwise, without the written permission of Haas Automation, Inc. No patent liability is assumed with respect to the use of the information contained herein. Moreover, because Haas Automation strives constantly to improve its high-quality products, the information contained in this manual is subject to change without notice. We have taken every precaution in the preparation of this manual; nevertheless, Haas Automation assumes no responsibility for errors or omissions, and we assume no liability for damages resulting from the use of the information contained in this publication.



This product uses Java Technology from Oracle Corporation and we request that you acknowledge that Oracle owns the Java Trademark and all Java related Trademarks and agree to comply with the trademark guidelines at [www.oracle.com/us/legal/third-party-trademarks/index.html](http://www.oracle.com/us/legal/third-party-trademarks/index.html).

Any further distribution of the Java programs (beyond this appliance/machine) is subject to a legally binding End User License Agreement with Oracle. Any use of the commercial features for production purposes requires a separate license from Oracle.

---

# LIMITED WARRANTY CERTIFICATE

Haas Automation, Inc.

Covering Haas Automation, Inc. CNC Equipment

Effective September 1, 2010

Haas Automation Inc. (“Haas” or “Manufacturer”) provides a limited warranty on all new mills, turning centers, and rotary machines (collectively, “CNC Machines”) and their components (except those listed below under Limits and Exclusions of Warranty) (“Components”) that are manufactured by Haas and sold by Haas or its authorized distributors as set forth in this Certificate. The warranty set forth in this Certificate is a limited warranty, it is the only warranty by Manufacturer, and is subject to the terms and conditions of this Certificate.

## Limited Warranty Coverage

Each CNC Machine and its Components (collectively, “Haas Products”) are warranted by Manufacturer against defects in material and workmanship. This warranty is provided only to an end-user of the CNC Machine (a “Customer”). The period of this limited warranty is one (1) year. The warranty period commences on the date the CNC Machine is installed at the Customer’s facility. Customer may purchase an extension of the warranty period from an authorized Haas distributor (a “Warranty Extension”), any time during the first year of ownership.

## Repair or Replacement Only

Manufacturer’s sole liability, and Customer’s exclusive remedy under this warranty, with respect to any and all Haas products, shall be limited to repairing or replacing, at the discretion of the Manufacturer, the defective Haas product.

## Disclaimer of Warranty

This warranty is Manufacturer’s sole and exclusive warranty, and is in lieu of all other warranties of whatever kind or nature, express or implied, written or oral, including, but not limited to, any implied warranty of merchantability, implied warranty of fitness for a particular purpose, or other warranty of quality or performance or noninfringement. All such other warranties of whatever kind are hereby disclaimed by Manufacturer and waived by Customer.

---

## **Limits and Exclusions of Warranty**

Components subject to wear during normal use and over time, including, but not limited to, paint, window finish and condition, light bulbs, seals, wipers, gaskets, chip removal system (e.g., augers, chip chutes), belts, filters, door rollers, tool changer fingers, etc., are excluded from this warranty. Manufacturer's specified maintenance procedures must be adhered to and recorded in order to maintain this warranty. This warranty is void if Manufacturer determines that (i) any Haas Product was subjected to mishandling, misuse, abuse, neglect, accident, improper installation, improper maintenance, improper storage, or improper operation or application, including the use of improper coolants or other fluids, (ii) any Haas Product was improperly repaired or serviced by Customer, an unauthorized service technician, or other unauthorized person, (iii) Customer or any person makes or attempts to make any modification to any Haas Product without the prior written authorization of Manufacturer, and/or (iv) any Haas Product was used for any non-commercial use (such as personal or household use). This warranty does not cover damage or defect due to an external influence or matters beyond the reasonable control of Manufacturer, including, but not limited to, theft, vandalism, fire, weather condition (such as rain, flood, wind, lightning, or earthquake), or acts of war or terrorism.

Without limiting the generality of any of the exclusions or limitations described in this Certificate, this warranty does not include any warranty that any Haas Product will meet any person's production specifications or other requirements, or that operation of any Haas Product will be uninterrupted or error-free. Manufacturer assumes no responsibility with respect to the use of any Haas Product by any person, and Manufacturer shall not incur any liability to any person for any failure in design, production, operation, performance, or otherwise of any Haas Product, other than repair or replacement of same as set forth in the warranty above.

## **Limitation of Liability and Damages**

Manufacturer will not be liable to Customer or any other person for any compensatory, incidental, consequential, punitive, special, or other damage or claim, whether in an action in contract, tort, or other legal or equitable theory, arising out of or related to any Haas product, other products or services provided by Manufacturer or an authorized distributor, service technician, or other authorized representative of Manufacturer (collectively, "authorized representative"), or the failure of parts or products made by using any Haas Product, even if Manufacturer or any authorized representative has been advised of the possibility of such damages, which damage or claim includes, but is not limited to, loss of profits, lost data, lost products, loss of revenue, loss of use, cost of down time, business good will, any damage to equipment, premises, or other property of any person, and any damage that may be caused by a malfunction of any Haas product. All such damages and claims are disclaimed by Manufacturer and waived by Customer. Manufacturer's sole liability, and Customer's exclusive remedy, for damages and claims for any cause whatsoever shall be limited to repair or replacement, at the discretion of Manufacturer, of the defective Haas Product as provided in this warranty.

---

Customer has accepted the limitations and restrictions set forth in this Certificate, including, but not limited to, the restriction on its right to recover damages, as part of its bargain with Manufacturer or its Authorized Representative. Customer realizes and acknowledges that the price of the Haas Products would be higher if Manufacturer were required to be responsible for damages and claims beyond the scope of this warranty.

### **Entire Agreement**

This Certificate supersedes any and all other agreements, promises, representations, or warranties, either oral or in writing, between the parties or by Manufacturer with respect to subject matter of this Certificate, and contains all of the covenants and agreements between the parties or by Manufacturer with respect to such subject matter. Manufacturer hereby expressly rejects any other agreements, promises, representations, or warranties, either oral or in writing, that are in addition to or inconsistent with any term or condition of this Certificate. No term or condition set forth in this Certificate may be modified or amended, unless by a written agreement signed by both Manufacturer and Customer. Notwithstanding the foregoing, Manufacturer will honor a Warranty Extension only to the extent that it extends the applicable warranty period.

### **Transferability**

This warranty is transferable from the original Customer to another party if the CNC Machine is sold via private sale before the end of the warranty period, provided that written notice thereof is provided to Manufacturer and this warranty is not void at the time of transfer. The transferee of this warranty will be subject to all terms and conditions of this Certificate.

### **Miscellaneous**

This warranty shall be governed by the laws of the State of California without application of rules on conflicts of laws. Any and all disputes arising from this warranty shall be resolved in a court of competent jurisdiction located in Ventura County, Los Angeles County, or Orange County, California. Any term or provision of this Certificate that is invalid or unenforceable in any situation in any jurisdiction shall not affect the validity or enforceability of the remaining terms and provisions hereof, or the validity or enforceability of the offending term or provision in any other situation or in any other jurisdiction.

---

## Customer Feedback

If you have concerns or questions regarding this Operator's Manual, please contact us on our website, [www.HaasCNC.com](http://www.HaasCNC.com). Use the "Contact Haas" link and send your comments to the Customer Advocate.

You can find an electronic copy of this manual and other useful information on our website in the "Resource Center". Join Haas owners online and be a part of the greater CNC community at these sites:



[diy.haascnc.com](http://diy.haascnc.com)  
The Haas Resource Center: DIY Documentation and Procedures



[haasparts.com](http://haasparts.com)  
Your Source for Genuine Haas Parts



[www.facebook.com/HaasAutomationInc](http://www.facebook.com/HaasAutomationInc)  
Haas Automation on Facebook



[www.twitter.com/Haas\\_Automation](http://www.twitter.com/Haas_Automation)  
Follow us on Twitter



[www.linkedin.com/company/haas-automation](http://www.linkedin.com/company/haas-automation)  
Haas Automation on LinkedIn



[www.youtube.com/user/haasautomation](http://www.youtube.com/user/haasautomation)  
Product videos and information



[www.flickr.com/photos/haasautomation](http://www.flickr.com/photos/haasautomation)  
Product photos and information



---

## Customer Satisfaction Policy

Dear Haas Customer,

Your complete satisfaction and goodwill are of the utmost importance to both Haas Automation, Inc. and the Haas distributor (HFO) where you purchased your equipment. Normally, your HFO will rapidly resolve any concerns you have about your sales transaction or the operation of your equipment.

However, if your concerns are not resolved to your complete satisfaction, and you have discussed your concerns with a member of the HFO's management, the General Manager, or the HFO's owner directly, please do the following:

Contact Haas Automation's Customer Service Advocate at 805-988-6980. So that we may resolve your concerns as quickly as possible, please have the following information available when you call:

- Your company name, address, and phone number
- The machine model and serial number
- The HFO name, and the name of your latest contact at the HFO
- The nature of your concern

If you wish to write Haas Automation, please use this address:

Haas Automation, Inc. U.S.A.  
2800 Sturgis Road  
Oxnard CA 93030  
Att: Customer Satisfaction Manager  
email: customerservice@HaasCNC.com

Once you contact the Haas Automation Customer Service Center, we will make every effort to work directly with you and your HFO to quickly resolve your concerns. At Haas Automation, we know that a good Customer-Distributor-Manufacturer relationship will help ensure continued success for all concerned.

International:

Haas Automation, Europe  
Mercuriusstraat 28, B-1930  
Zaventem, Belgium  
email: customerservice@HaasCNC.com

Haas Automation, Asia  
No. 96 Yi Wei Road 67,  
Waigaoqiao FTZ  
Shanghai 200131 P.R.C.  
email: customerservice@HaasCNC.com



---

## Declaration of Conformity

Product: CNC Lathes (Turning Centers)\*

\*Including all options factory- or field-installed by a certified Haas Factory Outlet (HFO)

Manufactured By: Haas Automation, Inc.  
2800 Sturgis Road, Oxnard CA 93030  
**805-278-1800**

We declare, in sole responsibility, that the above-listed products, to which this declaration refers, comply with the regulations as outlined in the CE directive for Machining Centers:

- Machinery Directive 2006 / 42 / EC
- Electromagnetic Compatibility Directive 2014 / 30 / EU
- Low Voltage Directive 2014 / 35 / EU
- Additional Standards:
  - EN 60204-1:2006 / A1:2009
  - EN 614-1:2006+A1:2009
  - EN 894-1:1997+A1:2008
  - CEN 13849-1:2015

RoHS: COMPLIANT by Exemption per producer documentation. Exempt by:

- a) Large scale stationary industrial tool
- b) Monitoring and control systems
- c) Lead as an alloying element in steel, aluminum, and copper

Person authorized to compile technical file:

Jens Thing

Address:

Haas Automation Europe  
Mercuriusstraat 28  
B-1930 Zaventem  
Belgium

---

USA: Haas Automation certifies this machine to be in compliance with the OSHA and ANSI design and manufacturing standards listed below. Operation of this machine will be compliant with the below-listed standards only as long as the owner and operator continue to follow the operation, maintenance, and training requirements of these standards.

- OSHA 1910.212 - *General Requirements for All Machines*
- ANSI B11.5-1984 (R1994) *Lathes*
- ANSI B11.19-2003 *Performance Criteria for Safeguarding*
- ANSI B11.22-2002 *Safety Requirements for Turning Centers and Automatic Numerically Controlled Turning Machines*
- ANSI B11.TR3-2000 *Risk Assessment and Risk Reduction - A Guideline to Estimate, Evaluate, and Reduce Risks Associated with Machine Tools*

CANADA: As the original equipment manufacturer, we declare that the listed products comply with regulations as outlined in the Pre-Start Health and Safety Reviews Section 7 of Regulation 851 of the Occupational Health and Safety Act Regulations for Industrial Establishments for machine guarding provisions and standards.

Further, this document satisfies the notice-in-writing provision for exemption from Pre-Start inspection for the listed machinery as outlined in the Ontario Health and Safety Guidelines, PSR Guidelines dated April 2001. The PSR Guidelines allow that notice in writing from the original equipment manufacturer declaring conformity to applicable standards is acceptable for the exemption from Pre-Start Health and Safety Review.



All Haas CNC machine tools carry the ETL Listed mark, certifying that they conform to the NFPA 79 Electrical Standard for Industrial Machinery and the Canadian equivalent, CAN/CSA C22.2 No. 73. The ETL Listed and cETL Listed marks are awarded to products that have successfully undergone testing by Intertek Testing Services (ITS), an alternative to Underwriters' Laboratories.



Haas Automation has been assessed for conformance with the provisions set forth by ISO 9001:2008. Scope of Registration: Design and Manufacture of CNC Machines Tools and Accessories, Sheet Metal Fabrication. The conditions for maintaining this certificate of registration are set forth in ISA's Registration Policies 5.1. This registration is granted subject to the organization maintaining compliance to the noted standard. The validity of this certificate is dependent upon ongoing surveillance audits.

## Original Instructions

---





## How to Use This Manual

To get the maximum benefit of your new Haas machine, read this manual thoroughly and refer to it often. The content of this manual is also available on your machine control under the HELP function.

**IMPORTANT:** Before you operate the machine, read and understand the Operator's Manual Safety chapter.

### Declaration of Warnings

Throughout this manual, important statements are set off from the main text with an icon and an associated signal word: "Danger," "Warning," "Caution," or "Note." The icon and signal word indicate the severity of the condition or situation. Be sure to read these statements and take special care to follow the instructions.

| Description  | Example  |
|--|--|
| <b>Danger</b> means that there is a condition or situation that <b>will cause death or severe injury</b> if you do not follow the instructions given.  | <br><b>DANGER:</b> No step. Risk of electrocution, bodily injury, or machine damage. Do not climb or stand on this area. |
| <b>Warning</b> means that there is a condition or situation that <b>will cause moderate injury</b> if you do not follow the instructions given.  | <br><b>WARNING:</b> Never put your hands between the tool changer and the spindle head.                                 |
| <b>Caution</b> means that <b>minor injury or machine damage could occur</b> if you do not follow the instructions given. You may also have to start a procedure over if you do not follow the instructions in a caution statement. | <br><b>CAUTION:</b> Power down the machine before you do maintenance tasks.   |
| <b>Note</b> means that the text gives <b>additional information, clarification, or helpful hints</b> .   | <br><b>NOTE:</b> Follow these guidelines if the machine is equipped with the optional extended Z-clearance table.       |

---

## Text Conventions Used in this Manual

| Description  | Text Example                                       |
|--|--|
| <b>Code Block</b> text gives program examples.   | G00 G90 G54 X0. Y0.;                               |
| A <b>Control Button Reference</b> gives the name of a control key or button that you are to press. | Press <b>[CYCLE START]</b> .                       |
| A <b>File Path</b> describes a sequence of file system directories.                                | <i>Service &gt; Documents and Software &gt;...</i> |
| A <b>Mode Reference</b> describes a machine mode.  | MDI  |
| A <b>Screen Element</b> describes an object on the machine's display that you interact with.       | Select the <b>SYSTEM</b> tab.                      |
| <b>System Output</b> describes text that the machine control displays in response to your actions. | PROGRAM END  |
| <b>User Input</b> describes text that you should enter into the machine control.                   | G04 P1.;   |
| <b>Variable n</b> indicates a range of non-negative integers from 0 to 9.                          | Dnn represents D00 through D99.                    |

---

# Contents

|                  |   |           |
|------------------|---|-----------|
| <b>Chapter 1</b> | <b>Safety</b>   | <b>1</b>  |
| 1.1              | General Safety Notes  | 1         |
| 1.1.1            | Summary of Types of Operation for Haas Automation Machine Tools | 2         |
| 1.1.2            | Read Before Operating   | 4         |
| 1.1.3            | Machine Environmental Limits                                    | 7         |
| 1.1.4            | Machine Noise Limits  | 7         |
| 1.2              | Unattended Operation  | 8         |
| 1.3              | Setup Mode  | 8         |
| 1.3.1            | Machine Behavior with the Door Open                             | 9         |
| 1.3.2            | Robot Cells   | 10        |
| 1.4              | Modifications to the Machine                                    | 10        |
| 1.5              | Improper Coolants   | 10        |
| 1.6              | Safety Decals   | 11        |
| 1.6.1            | Decal Symbols Reference   | 12        |
| 1.6.2            | Other Safety Information  | 16        |
| 1.7              | More Information Online   | 16        |
| <b>Chapter 2</b> | <b>Introduction</b>   | <b>17</b> |
| 2.1              | Chucker Lathe Features  | 17        |
| <b>Chapter 3</b> | <b>Operation</b>  | <b>21</b> |
| 3.1              | Introduction  | 21        |
| 3.2              | Moving the Chucker Lathe  | 21        |
| 3.3              | Machine Power-On  | 21        |
| 3.4              | Workholding   | 23        |
| 3.5              | ATT8 Turret Operation   | 27        |
| 3.5.1            | ATT8 Operational Test   | 27        |
| 3.5.2            | ATT8 Tool Change Recovery                                       | 28        |
| 3.6              | Bar Pusher Installation   | 29        |
| 3.6.1            | Bar Pusher Setup  | 30        |
| 3.6.2            | Bar Pusher Operation  | 34        |
| 3.6.3            | Bar Pusher Variables  | 35        |
| 3.7              | Chucker Lathe Parts Catcher Setup                               | 36        |
| 3.7.1            | Chucker Lathe Parts Catcher Operation                           | 37        |

---

|                  |                             |            |
|------------------|-----------------------------|------------|
| <b>Chapter 4</b> | <b>Maintenance</b>          | <b>.39</b> |
|                  | 4.1 Introduction            | .39        |
|                  | 4.2 CL Lubrication          | .39        |
|                  | 4.3 Troubleshooting         | .39        |
|                  | 4.4 More Information Online | .41        |
|                  | <b>Index</b>                | <b>.43</b> |



# Chapter 1: Safety

## 1.1 General Safety Notes

**CAUTION:**

*Only authorized and trained personnel may operate this equipment. You must always act in accordance with the Operator's manual, safety decals, safety procedures, and instructions for safe machine operation. Untrained personnel present a hazard to themselves and the machine.*

**IMPORTANT:**

*Do not operate this machine until you have read all warnings, cautions, and instructions.*

**CAUTION:**

*The sample programs in this manual have been tested for accuracy, but they are for illustrative purposes only. The programs do not define tools, offsets, or materials. They do not describe workholding or other fixturing. If you choose to run a sample program on your machine, do so in Graphics mode. Always follow safe machining practices when you run an unfamiliar program.*

All CNC machines contain hazards from rotating work, loosely clamped parts, belts and pulleys, high voltage electricity, noise, and compressed air. You must always follow basic safety precautions to reduce the risk of personal injury and mechanical damage.

The work area must be adequately illuminated to allow clear view and safe operation of the machine. This includes the operator work area and all areas of the machine that might be accessed during maintenance or cleaning. Adequate illumination is the responsibility of the user.

Cutting tools, workholding, workpiece and coolant are beyond the scope and control of Haas Automation, Inc. Each of these potential hazards associated with it (sharp edges, heavy lifting considerations, chemical composition, etc) and it is the responsibility of the user to take appropriate action (PPE, training, etc).

Cleaning of the machine is required during normal use and prior to maintenance or repair. Optional equipment is available to aid cleaning such as washdown hoses, chip conveyors and chip augers. Safe use of this equipment requires training and might require appropriate PPE and is the responsibility of the user.

This operator's manual is intended as a reference guide and is not to be the sole source of training. Complete operator training is available from the authorized Haas distributor.

## 1.1.1 Summary of Types of Operation for Haas Automation Machine Tools

Haas CNC Lathes are intended for cutting and shaping of metals and other hard materials. They are general purpose in nature and a list of all of those materials and types of cutting would never be complete. Almost all cutting and shaping is performed by a rotating part clamped in a chuck. The tools are held on a turret. Some cutting operations require liquid coolant. That coolant is also an option depending on the type of cutting.

Operations of Haas Lathes are separated into three areas. They are: Operations, Maintenance, and Service. Operations and Maintenance are intended to be performed by a trained and qualified machine operator. This Operator's Manual contains some of the information necessary to operate the machine. All other machine operations are to be considered Service. Service is only to be performed by specially trained service personnel.

Operation of this machine consists of the following:

1. Machine Setup
  - Machine setup is done to initially set up the tools, offsets, and fixtures required to perform a repetitive function that later is called machine operation. Some machine setup functions can be done with the door open but are limited to "hold to run".
2. Machine operating in Automatic Mode
  - Automatic operation is initiated with Cycle-Start and can only be done with the doors closed.
3. Operator loading and unloading of materials (parts)
  - Parts loading and unloading is what precedes and follows an automatic operation. This must be done with the doors open and all machine automatic motion is stopped when the door is open.
4. Operator loading and unloading of cutting tools
  - Tool loading and unloading is done less often than setup. It is often required when a tool has become worn and must be replaced.

Maintenance only consists of the following:

1. Adding and maintaining condition of coolant
  - Adding coolant and maintaining coolant concentration is required at regular intervals. This is a normal operator function and is either done from a safe location outside of the work enclosure or with the doors open and the machine stopped.
2. Adding lubricants

- Adding lubricants for spindle and axes is required at regular intervals. These are often months or years in length. This is a normal operator function and is always done from a safe location outside of the work enclosure.
3. Cleaning chips out of the machine
    - Cleaning out of chips is required at intervals dictated by the type of machining performed. This is a normal operator function. It is performed with the doors open and all of the machine operation is stopped.

Service only consists of the following:

1. Repairing of a machine that is not operating correctly
  - Any machine that is not operating correctly requires service by factory trained personnel. This is never an operator function. It is not considered maintenance. Installation and service instructions are provided separately from the Operator's Manual.
2. Machine moving, unpacking, and installation
  - Haas machines are shipped to a user's location almost ready to operate. They still require a trained service person to complete the installation. Installation and service instructions are provided separately from the Operator's Manual.
3. Machine packing
  - Machine packing for shipment requires the same packing material supplied by Haas in the original shipment. Packing requires a trained service person to complete the installation. Shipping instructions are provided separately from the Operator's Manual.
4. Decommission, dismantle and disposal
  - Machine is not expected to be disassembled for shipment; it can be moved in its entirety in the same manner in which it was installed. Machine can be returned to the manufacturer's distributor for disposal; manufacturer accepts any/all components for recycling per Directive 2002/96/EC.
5. End-of-life disposal
  - End-of-life disposal must conform to the laws and regulations in the region the machine is located. This is a jointly the responsibility of the owner and seller of the machine. The risk analysis does not address this phase.

## 1.1.2 Read Before Operating



**DANGER:**

*Do not enter the machining area any time the machine is in motion, or at any time that machine motion is possible. Severe injury or death may result. Motion is possible when the power is on and the machine is not in [EMERGENCY STOP].*

Basic safety:

- This machine can cause severe bodily injury.
- This machine is automatically controlled and may start at any time.
- Consult your local safety codes and regulations before you operate the machine. Contact your dealer if you have questions about safety issues.
- It is the machine owner's responsibility to make sure that everyone who is involved in installing and operating the machine is fully acquainted with the operation and safety instructions provided with the machine, BEFORE they work with the machine. The ultimate responsibility for safety rests with the machine owner and the individuals who work with the machine.
- Use appropriate eye and ear protection when you operate the machine.
- Use appropriate gloves to remove processed material and to clean the machine.
- Replace windows immediately if they are damaged or severely scratched.

Electrical safety:

- The electrical power must meet the required specifications. Attempting to run the machine from any other source can cause severe damage and will void the warranty.
- The electrical panel should be closed and the key and latches on the control cabinet should be secured at all times, except during installation and service. At those times, only qualified electricians should have access to the panel. When the main circuit breaker is on, there is high voltage throughout the electrical panel (including the circuit boards and logic circuits) and some components operate at high temperatures; therefore, extreme caution is required. Once the machine is installed, the control cabinet must be locked, with the key available only to qualified service personnel.
- Do not reset a circuit breaker until the reason for the fault is investigated and understood. Only Haas-trained service personnel should troubleshoot and repair Haas equipment.
- Do not press **[POWER UP]** on the control pendant before the machine is fully installed.

Operation Safety:

- Do not operate the machine unless the doors are closed and the door interlocks are functioning correctly.

- Check for damaged parts and tools before you operate the machine. Any part or tool that is damaged should be properly repaired or replaced by authorized personnel. Do not operate the machine if any component does not appear to be functioning correctly.
- When a program runs, the tool turret can move rapidly at any time.
- Improperly clamped parts machined at high speeds/feeds may be ejected and puncture the enclosure. It is not safe to machine oversized or marginally clamped parts.

Release of person trapped in the machine:

- No person should every be located inside the machine during operation
- In the unlikely event a person is trapped inside the machine the emergency stop button should be immediately depressed and the person removed

Recover from a jam or blockage:

- Of the chip conveyor - Follow the cleaning instructions on the Haas Resource Center ([diy.haascnc.com](http://diy.haascnc.com)). If necessary, close the doors and reverse the conveyor so the jammed part or material is accessible, and remove. Use lifting equipment or get assistance for lifting heavy and awkward parts.
- Of a tool and material/part - Close the doors, press **[RESET]** to clear and displayed alarms. Jog the axis so the tool and material are clear.
- If the alarms do not reset or you are unable to clear a blockage, contact your Haas Factory Outlet (HFO) for assistance.

Follow these guidelines when you work with the machine:

- Normal operation - Keep the door closed and guards in place (for non-enclosed machines) while the machine operates.
- Part loading and unloading – An operator opens the door, completes the task, closes the door, and then presses **[CYCLE START]** (starting automatic motion).
- Machining job set-up – When set-up is complete, turn the set-up key to lock out set-mode and remove the key.
- Maintenance / Machine Cleaner– Press **[EMERGENCY STOP]** or **[POWER OFF]** on the machine before you enter the enclosure.
- Tool loading or unloading – A machinist enters the machining area to load or unload tools. Exit the area completely before automatic movement is commanded (for example, **[NEXT TOOL]**, **[TURRET FWD]**, **[TURRET REV]**).

Chuck safety:



**DANGER:**

*Improperly clamped parts or oversized parts may be ejected with deadly force.*

- Do not exceed the chuck's rated speed. Higher speeds reduce chuck clamping force.

## General Safety Notes

---

- Unsupported barstock must not extend outside the drawtube.
- Grease the chuck weekly. Follow the chuck manufacturer's instructions for regular service.
- Chuck jaws must not protrude beyond the diameter of the chuck.
- Do not machine parts larger than the chuck.
- Follow all of the chuck manufacturer's warnings regarding the chuck and workholding procedures.
- Hydraulic pressure must be set correctly to securely hold the work piece without distortion.
- Improperly clamped parts at high velocity may puncture the safety door. You must reduce the spindle speed to protect the operator when performing dangerous operations (e.g. turning oversized or marginally clamped parts).

Periodic maintenance of machine safety features:

- Inspect door interlock mechanism for proper fit and function.
- Inspect safety windows and enclosure for damage or leaks.
- Verify all enclosure panels are in place.

Door Safety Interlock maintenance:

- Inspect the door interlock, verify the door interlock key is not bent, misaligned, and that all fasteners are installed.
- Inspect the door interlock itself for any signs of obstruction or misalignment.
- Immediately replace any components of the Door Safety Interlock system that do not meet this criteria.

Door Safety Interlock testing:

- With the machine in run mode, close the machine door, run the spindle at 100 RPM, pull the door and verify the door does not open.

Machine Enclosure and Safety Glass maintenance and testing:

Routine Maintenance:

- Visually inspect the enclosure and safety glass for any signs of distortion, breakage or other damage.
- Replace the Lexan windows after 7 years or if they are damaged or severely scratched.
- Keep all safety glass and machine windows clean to allow proper viewing of the machine during operations.
- A daily visual inspection of the machine enclosure to verify all panels are in place should be performed.

Testing of machine enclosure:

- No testing of the machine enclosure is necessary.

### 1.1.3 Machine Environmental Limits

This table lists the environmental limits for safe operation:

#### T1.1: Environmental Limits (Indoor Use Only)

|                       | Minimum                      | Maximum                      |
|-----------------------|------------------------------|------------------------------|
| Operating Temperature | 41 °F (5.0 °C)               | 122 °F (50.0 °C)             |
| Storage Temperature   | -4 °F (-20.0 °C)             | 158 °F (70.0 °C)             |
| Ambient Humidity      | 20% relative, non-condensing | 90% relative, non-condensing |
| Altitude              | Sea Level                    | 6,000 ft. (1,829 m)          |



**CAUTION:** Do not operate the machine in explosive atmospheres (explosive vapors and/ or particulate matter).

### 1.1.4 Machine Noise Limits



**CAUTION:** Take precautions to prevent hearing damage from machine/machining noise. Wear ear protection, change your application (tooling, spindle speed, axis speed, fixturing, programmed path) to reduce noise, or restrict access to machine area during cutting.

Typical noise levels at the operator's position during normal operation are as follows:

- **A-Weighted** sound pressure level measurements will be 69.4dB or lower.
- **C-Weighted** instantaneous sound pressure levels will be 78.0dB or lower.
- **LwA** (sound power level A-weighted) will be 75.0dB or lower.



**NOTE:** Actual noise levels while cutting material are greatly affected by the user's choice of material, cutting tools, speeds and feeds, workholding and other factors. These factors are application specific and are controlled by the user, not Haas Automation Inc.

## 1.2 Unattended Operation

Fully enclosed Haas CNC machines are designed to operate unattended; however, your machining process may not be safe to operate unmonitored.

As it is the shop owner's responsibility to set up the machine safely and use best practice machining techniques, it is also the owner's responsibility to manage the progress of these methods. You must monitor your machining process to prevent damage, injury, or loss of life if a hazardous condition occurs.

For example, if there is the risk of fire due to the material machined, then you must install an appropriate fire suppression system to reduce the risk of harm to personnel, equipment, and the building. Contact a specialist to install monitoring tools before machines are allowed to run unattended.

It is especially important to select monitoring equipment that can immediately detect a problem and perform an appropriate action without human intervention.

## 1.3 Setup Mode

All Haas CNC machines are equipped with locks on the operator doors and a key switch on the side of the control pendant to lock and unlock setup mode. Generally, setup mode status (locked or unlocked) affects how the machine operates when the doors are opened.

Setup mode should be locked out (the keyswitch in the vertical, locked position) at most times. In locked mode, the enclosure doors are locked closed during CNC program execution, spindle rotation or axis movement. The doors automatically unlock when the machine is not in cycle. Many machine functions are unavailable with the door open.

When unlocked, setup mode allows a skilled machinist more access to the machine to set up jobs. In this mode, machine behavior is dependent on whether the doors are opened or closed. Opening the doors when the machine is in cycle stops motion and reduces spindle speed. The machine allows several functions in setup mode with the doors opened, usually at reduced speed. The following charts summarize the modes and allowed functions.

Machines with software version 100.17.000.1016 or higher have Parameter 2083, Setup Mode Safety Type, that affects the machine's Setup mode. When Parameter 2083 is set to **Normal**, the machine Setup and Run modes behave as outlined in the table that follows. When Parameter 2083 is set to **strict**, both the Setup and Run modes adhere to the Run mode behaviors. Contact your local Haas Factory Outlet to set Parameter 2083 to your desired setting on your machine.



**DANGER:**

*Do not attempt to override safety features. Doing so makes the machine unsafe and voids the warranty.*







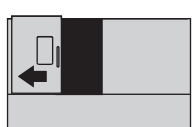
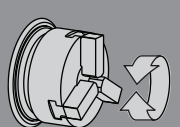
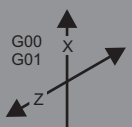
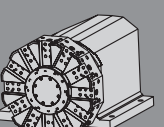

### 1.3.1 Machine Behavior with the Door Open

For safety, machine operations stop when the door is open and the setup keyswitch is locked. The unlocked position allows limited machine functions with the door open.

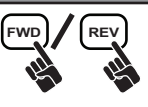
#### T1.2: Setup / Run Mode Limited Overrides with the Machine Doors Open

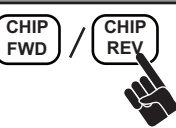
| Machine Function                        | Keyswitch Locked  | Keyswitch Unlocked  |
|---|---|---|
| Maximum Rapid                           | Not allowed.  | Not allowed.  |
| Cycle Start                             | Not allowed. No machine motion or program execution.  | Not allowed. No machine motion or program execution.                              |
| Spindle [FWD] / [REV]                   | Allowed, but you must press and hold [FWD] or [REV]. Maximum 250-500 RPM, depending on the lathe model. | Allowed, but maximum 250-500 RPM, depending on the lathe model.                   |
| Tool Change                             | Not allowed.  | Not allowed.  |
| Next Tool                               | Not allowed.  | Not allowed.  |
| Opening door while a program is running | Not allowed. The door is locked.  | Allowed, but axis motion stops and the spindle slows to a maximum of 250-500 RPM. |
| Conveyor motion                         | Allowed, but you must press and hold [CHIP REV] to run in reverse.                                      | Allowed, but you must press and hold [CHIP REV] to run in reverse.                |

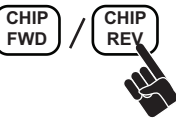
|  |                      |  |   |  |
|---|---|---|---|---|
|  | <br>250-500 RPM Max. | 0%  |  |  |
|  | 250-500 RPM Max.  | 0%  |  |  |

### **1.3.2 Robot Cells**

A machine in a robot cell is allowed to run a program while the door is open, regardless of the position of the Run-Setup key. While the door is open, the spindle speed is limited to the lower of the factory RPM limit or Setting 292, Door Open Spindle Speed Limit. If the door is opened while the spindle RPM is above the limit, the spindle will decelerate to the limit RPM. Closing the door removes the limit and the programmed RPM is restored.

This open-door condition is allowed only while a robot communicates with the CNC machine. Typically, an interface between the robot and the CNC machine addresses the safety of both machines.

Robot cell setup is beyond the scope of this manual. Work with a robot-cell integrator and your HFO to correctly set up a safe robot cell.

## **1.4 Modifications to the Machine**

Haas Automation, Inc. is not responsible for damage caused by modifications you make to your Haas machine(s) with parts or kits not manufactured or sold by Haas Automation, Inc. The use of such parts or kits may void your warranty.

Some parts or kits manufactured or sold by Haas Automation, Inc. are considered user-installable. If you choose to install these parts or kits yourself, be sure to completely read the accompanying installation instructions. Make sure you understand the procedure, and how to do it safely, before you begin. If you have any doubts about your ability to complete the procedure, contact your Haas Factory Outlet (HFO) for assistance.

## **1.5 Improper Coolants**

Coolant is an important part of many machining operations. When it is correctly used and maintained, coolant can improve part finish, lengthen tool life, and protect machine components from rust and other damage. Improper coolants, however, can cause significant damage to your machine.

Such damage can void your warranty, but it can also introduce hazardous conditions to your shop. For example, coolant leaks through damaged seals could create a slipping hazard.

Improper coolant use includes, but is not limited to, these points:

- Do not use plain water. This causes machine components to rust.
- Do not use flammable coolants.
- Do not use straight or “neat” mineral-oil products. These products cause damage to rubber seals and tubing throughout the machine. If you use a minimum-quantity lubrication system for near-dry machining, use only the recommended oils.

Machine coolant must be water-soluble, synthetic oil-based or synthetic-based coolant or lubricant.

**NOTE:**

*Be sure to maintain your coolant mixture to keep the coolant concentrate at acceptable levels. Improperly maintained coolant mixtures can allow machine components to rust. Rust damage is not covered by your warranty.*

Ask your HFO or your coolant dealer if you have questions about the specific coolant that you plan to use. The Haas Resource Center website has videos and other general information about coolant use and maintenance. You can also scan the code below with your mobile device to directly access this information.



## 1.6 Safety Decals

The Haas factory puts decals on your machine to quickly communicate possible hazards. If decals become damaged or worn, or if you need additional decals to emphasize a particular safety point, contact your Haas Factory Outlet (HFO).

**NOTE:**

*Never alter or remove any safety decal or symbol.*

Be sure to familiarize yourself with the symbols on the safety decals. The symbols are designed to quickly tell you the type of information they give:

- Yellow Triangle - Describes a hazard.
- Red Circle with Slash-Through - Describes a prohibited action.
- Green Circle - Describes a recommended action.
- Black Circle - Gives information about machine or accessory operation.

## Safety Decals



F1.1: Example Safety Decal Symbols: [1] Hazard Description, [2] Prohibited Action, [3] Recommended Action.





### 1.6.1 Decal Symbols Reference



This section gives explanations and clarifications for the safety symbols you will see on your machine.

T1.3: Hazard Symbols – Yellow Triangles



| Symbol  | Description   |
|---|---|
|  | Moving parts can entangle, trap, crush, and cut.<br>Keep all parts of your body away from machine parts when they move, or whenever motion is possible. Motion is possible when the power is on and the machine is not in <b>[EMERGENCY STOP]</b> .<br>Secure loose clothing, hair, etc.<br>Remember that automatically controlled devices can start at any time. |
|  | Do not extend unsupported bar stock out the rear of the drawtube.<br>Unsupported bar can bend and “whip”. A whipping bar can cause severe injury or death.  |
|  | The Regen is used by the spindle drive to dissipate excess power and will get hot.<br>Always use care around the Regen.   |

| Symbol   | Description  |
|--|--|
|   | <p>There are high voltage components on the machine that can cause electrical shock.<br/>Always use care around high voltage components.</p>   |
|   | <p>Always securely clamp workpieces in the chuck or collet. Properly fasten chuck jaws.</p>  |
|  | <p>Secure loose clothing, hair, jewelry, etc. Do not wear gloves around rotating machine components. You can be pulled into the machine, resulting in severe injury or death.<br/>Automatic motion is possible when the power is on and the machine is not in <b>[EMERGENCY STOP]</b>.</p> |





**T1.4:** Prohibited Action Symbols – Red Circles with Slash-Through

| Symbol  | Description   |
|---|---|
|  | <p>Do not enter the machine enclosure when the machine is capable of automatic motion.<br/>When you must enter the enclosure to complete tasks, press <b>[EMERGENCY STOP]</b> or power off the machine. Put a safety tag on the control pendant to alert other people that you are inside the machine, and that they must not turn on or operate the machine.</p> |
|  | <p>Do not machine ceramics.</p>   |

## Safety Decals

| Symbol   | Description   |
|--|---|
|  A black and white line drawing of a lathe chuck with its jaws extended. A red circle with a diagonal slash is superimposed over the drawing, indicating that this action is prohibited.  | Do not use chuck jaw extensions. Do not extend chuck jaws beyond the chuck face.  |
|  A black and white line drawing showing a hand reaching towards a tailstock. Red lines radiating from the hand indicate a hazard. A red circle with a diagonal slash is superimposed over the drawing, indicating that this action is prohibited. | Keep your hands and body away from the area between the tailstock and workholding when automatic motion is possible.                          |
|  A red circle with a diagonal slash. Inside the circle, the text "100% H <sub>2</sub> O" is written in black.  | Do not use pure water as coolant. This will cause machine components to rust.<br>Always use a rust-inhibitive coolant concentrate with water. |

T1.5: Recommended Action Symbols – Green Circles

| Symbol  | Description  |
|---|--|
|    | <p>Keep the machine doors closed.</p>  |
|    | <p>Always wear safety glasses or goggles when you are near a machine.<br/>Airborne debris can cause eye damage.<br/>Always wear hearing protection when you are near a machine.<br/>Machine noise can exceed 70 dBA.</p> |
|  | <p>Read and understand the operator's manual and other instructions included with your machine.</p>  |
|  | <p>Grease and maintain the chuck regularly. Follow the manufacturer's instructions.</p>  |

## More Information Online

---

### T1.6: Informational Symbols – Black Circles

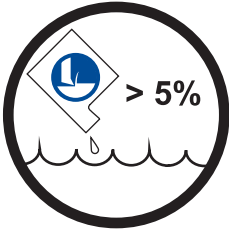
| Symbol  | Description  |
|---|--|
|  | <p>Maintain the recommended coolant concentration.</p> <p>A “lean” coolant mixture (less concentrated than recommended) may not effectively prevent machine components from rusting.</p> <p>A “rich” coolant mixture (more concentrated than recommended) wastes coolant concentrate without further benefit over the recommended concentration.</p> |

### 1.6.2 Other Safety Information

You may find other decals on your machine, depending on the model and options installed. Be sure to read and understand these decals. These are examples of other safety decals in English. You can contact your Haas Factory Outlet (HFO) to get these decals in other languages.

## 1.7 More Information Online

For updated and supplemental information, including tips, tricks, maintenance procedures, and more, go to [DIY.HaasCNC.com](http://DIY.HaasCNC.com).

You can also scan this code with your mobile device to directly access the “Best Practices” page on the Resource Center, which includes information about safety.





# Chapter 2: Introduction

## 2.1 Chucker Lathe Features

The following figures show some of the standard and optional features of your Haas lathe.



**NOTE:**

*These figures are representative only; your machine's appearance may vary depending on the model and installed options.*

## Chucker Lathe Features

---

**F2.1:** Chucker Lathe Features (CL-1 shown front view)

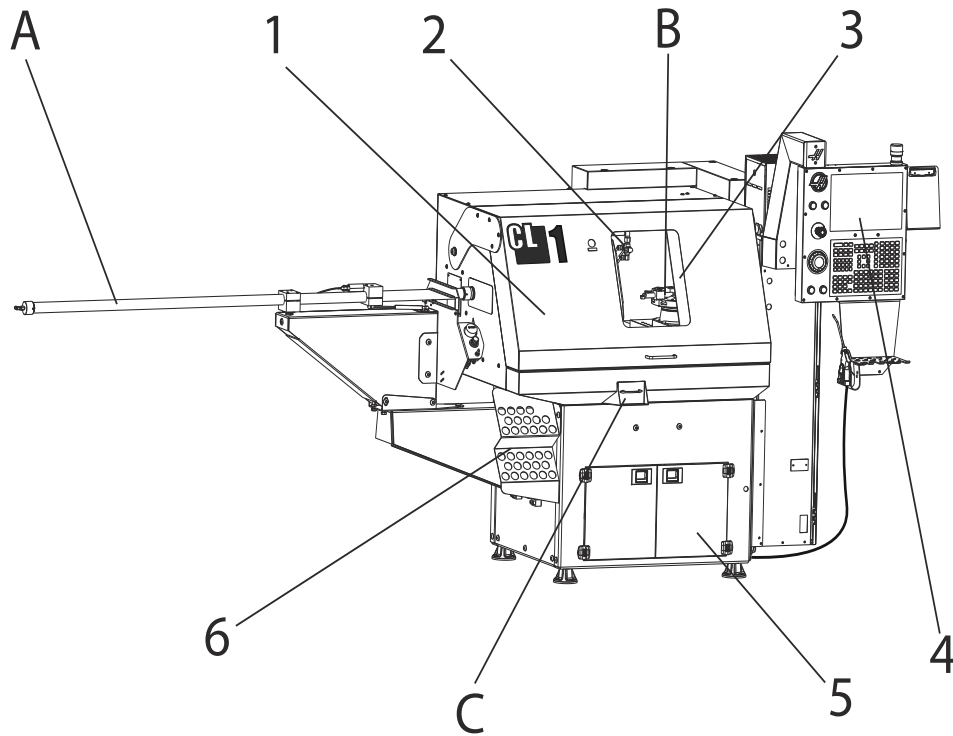

- |   |                             |
|---|-----------------------------|
| 1. Operator Door                            | 6. Collet Holder            |
| 2. Coolant Nozzles                          | A. Bar Pusher (optional)    |
| 3. Auto Door (optional) / Manual Door (std) | B. ATT8 Tool Changer        |
| 4. Control Pendant                          | C. Parts Catcher (optional) |
| 5. Coolant Tank/Pump (optional)             |                             |

F2.2: Detail A - Bar Pusher

- 1. Bar Pusher Tube
- 2. End of Bar Pressure Switch
- 3. Collet Holder
- 4. Manual Feed Switch
- 5. Regulator
- 6. Air Pressure Gauge

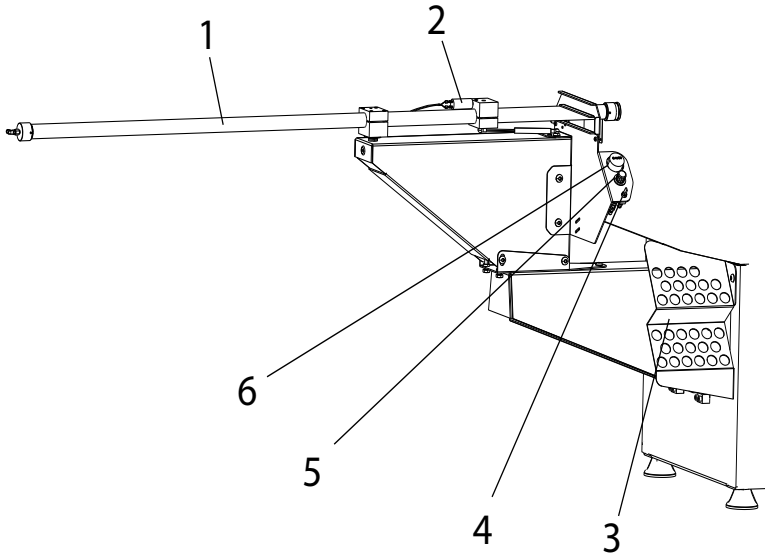

**Chucker Lathe Features**

---

**F2.3:** Detail B - ATT8 Tool Changer

- 1. Tool Holders
- 2. 8 Station Turret
- 3. Turret Motor Cover
- 4. ATT8 Mounting Base

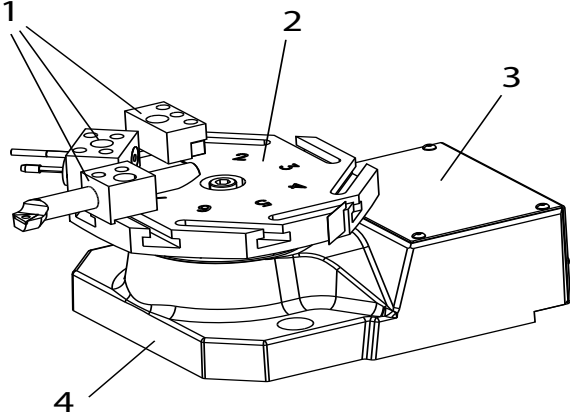

**F2.4:** Detail C - Parts Catcher

- 1. Part Chute
- 2. Side-to-Side Adjustment Handle
- 3. Parts Tray

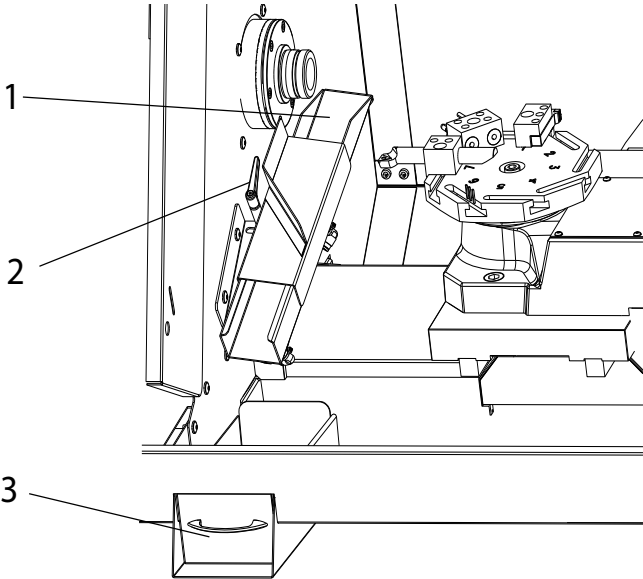

# Chapter 3: Operation

## 3.1 Introduction

You will find the majority of the information on how to operate your Chucker Lathe in the Lathe Operator's Manual. Operational differences are described in the following sections:

- Machine Power-On
- ATT8 Turret Operation
- Bar Pusher Operation
- Parts Catcher Operation

## 3.2 Moving the Chucker Lathe

Warning

The Chucker Lathe has a high center of gravity. Move the machine slowly and carefully to prevent it from falling over.

1. You will need a pallet jack that has at least 1500 lb capacity and forks that will fit in the space between the Chucker Lathe's leveling pads (22.5", 571 mm).
2. Lift the Chucker Lathe from the control cabinet side. Carefully move the Chucker Lathe to its operating location, then lower it onto the leveling pads.
3. Make sure there is equal tension on each leveling screws.

## 3.3 Machine Power-On

Follow this procedure to turn on a Chucker Lathe for the first time.

Before you do this procedure, make sure that possible crash areas, such as the spindle, and tool changer are clear and that all shipping brackets have been removed.

## Machine Power-On

---

### F3.1: Power-Up X/Z Axis Home Movement and Possible Crash Areas: [1] spindle, [2] tool changer

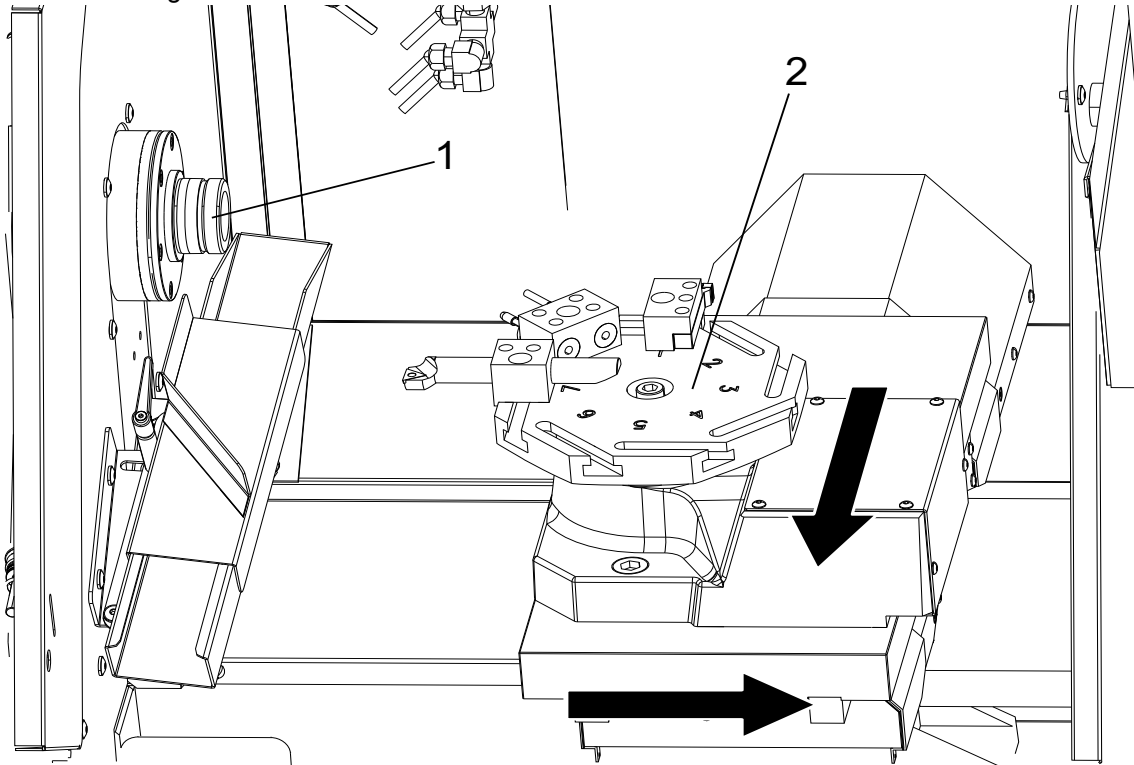

1. Press and hold **[POWER ON]** until you see the Haas logo on the screen. After a self-test and boot sequence, the display shows the startup screen. The startup screen gives basic instructions to start the machine. Press **[CANCEL]** to dismiss the screen. You can also press **[F1]** to disable it.
2. Turn **[EMERGENCY STOP]** clockwise to reset it.
3. Press **[RESET]** to clear the startup alarms. If you cannot clear an alarm, the machine may need service. Contact your Haas Factory Outlet (HFO) for assistance.
4. Close the doors.



#### **WARNING:**

*Before you do the next step, remember that automatic motion begins immediately when you press **[POWER UP/RESTART]**. Make sure the motion path is clear. Stay away from the spindle, tool changer.*

5. Press [POWER UP/RESTART].



The axes move slowly until the machine finds the home switch for each axis. This establishes the machine home position.

The control is now in **OPERATION : MEM** mode.

## 3.4 Workholding

### Installing a Collet

NOTE: The numbers in brackets in the following set of instructions refer to the numbered parts listed in the following illustration.

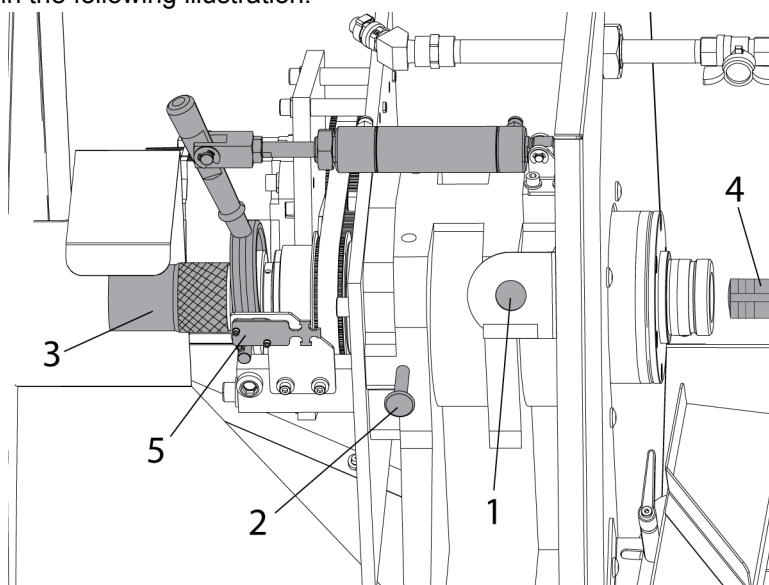

1. Open the large operator door.
2. Press the CHUCK button [1] to unclamp the collet. The message “UNCLAMPED” appears on the control screen.
3. Push on the spindle lock pin [2] and turn the spindle by hand until the pin engages and the spindle can not turn.

4. Turn the knurled knob [3] at the end of the drawbar assembly clockwise until you can insert the collet [4] into the spindle nose. The spindle contains a collet anti-rotation pin to align the collet for installation. Turn the collet in the spindle head until you feel the anti-rotation pin engage with the pin slot on the collet.

NOTE: Make sure the collet is correctly aligned with the anti-rotation pin. An incorrectly aligned collet can damage the spindle and the collet.

**F3.2:** Collet Anti-rotation Pin: [1] Collet, [2] Collet anti-rotation pin slot.

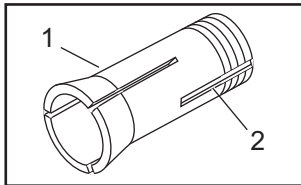

5. Turn the knurled knob clockwise to draw the collet into the spindle. You will feel the draw bar tighten on the collet threads.

### Inserting a Workpiece

1. Put a part into the open collet.
2. Turn the knurled knob clockwise until the part is tight in the collet, then loosen the knob about one half-turn.
3. Press the CHUCK button. Make sure that the part is clamped in the collet.

### WARNING!

If the part is in place, but the collet and the part are not tight, do not operate the spindle.

4. Next, find the correct clamping force for your stock:
  - a. Press the CHUCK button to unclamp the collet ('UNCLAMPED' will be displayed on the screen).
  - b. Turn the knurled knob slightly; clockwise to tighten, counterclockwise to loosen.
  - c. Press the CHUCK button to clamp the collet.

The part is properly clamped when the draw bar arm hesitates during clamping, then continues to the end of the piston stroke. The mechanism makes a distinct sound when it clamps.

### WARNING!

If the arm does not go to full stroke, the collet has not properly clamped the part. The machine will not start the spindle until the micro switch [5] is tripped when the collet is clamped.

### WARNING!



If the arm does not hesitate while the part is clamped, the part will not be clamped tightly and it may spin when the tool makes contact. The part may also come out, causing damage or injury.

5. Do a couple of test clamps to make sure the collet is set at the correct tension.

NOTE: A standard 5C collet has a maximum adjustment range of only around 0.010". Part diameter variation or bar stock variations may therefore cause improper clamping. Good machining practices include regular inspection of bar stock diameter and/or adjustment of the collet.

6. Make sure to disengage the spindle lock pin before you try to operate the spindle.

### **Removing a Collet**

1. Open the large operator door and press the CHUCK button to unclamp the collet.
2. Push on the pin and turn the spindle by hand until the pin engages and the spindle can not turn.
3. Turn the knurled knob counterclockwise to begin loosening the collet. If there is bar stock in the collet, remove it from the collet as soon as it is loose enough.
5. Keep turning the knurled knob until the collet is loose, then remove the collet from the spindle.

### **Collet Use Tips**

Some collets hold certain materials better than others, so make sure to choose the proper collet for the application (i.e., serrated vs. smooth).

Standard collets pull back while they clamp material. If the part outer diameter (OD) varies, pullback (Z-distance) will vary.

Because of their design, dead length (exact length) collets position parts more consistently.

NOTE: Do not try to adjust the length of the draw bar arm air cylinder. Contact Haas Service for adjustment. If roller bearings spin while the spindle turns, contact Haas Service.

### **Installing a Chuck**

1. Engage the spindle lock pin while you do this procedure.
2. Attach the chuck to its back plate with the Socket Head Cap Screws (SHCS) supplied in the kit. Torque the SHCS to 25 ft-lbs.

## Workholding

---

**F3.3:** Installing a Chuck: [1] Socket-head cap screw (SCHS), [2] Face plate, [3] Chuck.

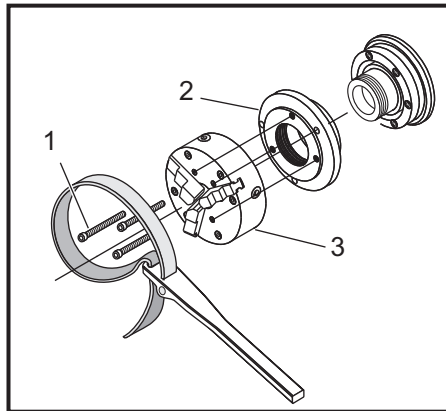

3. Gently turn the assembly onto the spindle nose until it seats against the spindle shoulder. Tighten the chuck with a strap wrench to approximately 70 ft-lbs.

### Chuck Alignment

Follow this procedure to eliminate runout in the chuck.

1. Place a precision test bar in the chuck.
2. Set a dial indicator against the test bar and rotate the chuck.
3. Use the chuck adjustment screws to align the chuck until the dial indicator reads zero

### Chuck Removal

1. Engage the spindle lock pin.
2. Use a strap wrench to unscrew the chuck. To avoid damaging the chuck, do not pry against the chuck jaws.

## 3.5 ATT8 Turret Operation

**F3.4:** ATT8 Turret Detail: [1] Turret, [2] tool-retention screws, [3] tool holder, [4] tool,

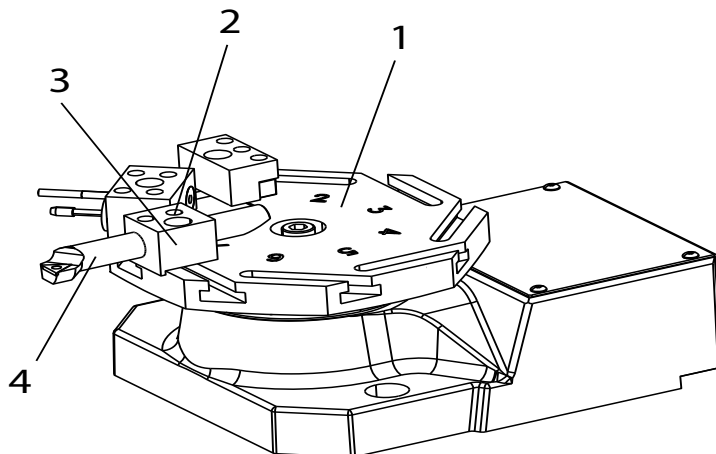

**NOTE:**

*The ATT8 has a 1/2 inch turning tool height from the top of the turret.*

**To set up the ATT8 turret:**

1. Loosen the tool-retention screws [2]. Put the tool [4] into the tool holder [3] and tighten the tool-retention screws [2].



**CAUTION:**

*If you use the air gun to remove chips and coolant from the turret, do not blow air into the ring cover at the base of the turret. Compressed air can force chips and coolant into the mechanism. This damages the unit.*

### 3.5.1 ATT8 Operational Test

Use this program to test the tool changer:

1. Enter the following code:

```
%  
T1 ;  
T2 ;  
T3 ;  
T4 ;  
T5 ;  
T6 ;  
T7 ;  
T8 ;  
T7 ;  
T6 ;  
T5 ;  
T4 ;  
T3 ;  
T2 ;  
M99 ;  
;  
;  
;  
%
```



**NOTE:**

Use T-address codes to operate the tool changer. For example, *T303* rotates the tool changer to the number 3 tool position, and uses offset 3. Add the T-address code to the program like the other lines of code. Refer to the *Lathe Operator's manual* for more information on the T-codes and tool offsets.

2. Press [CYCLE START].

### 3.5.2 ATT8 Tool Change Recovery

To recover the tool changer from an incomplete tool change:

1. Press [MDI DNC].



**CAUTION:**

The tool changer moves rapidly when you push [TURRET FWD] or [TURRET REV]. To prevent injury, give the turret sufficient clearance.

2. Press [TURRET FWD] or [TURRET REV].

## 3.6 Bar Pusher Installation

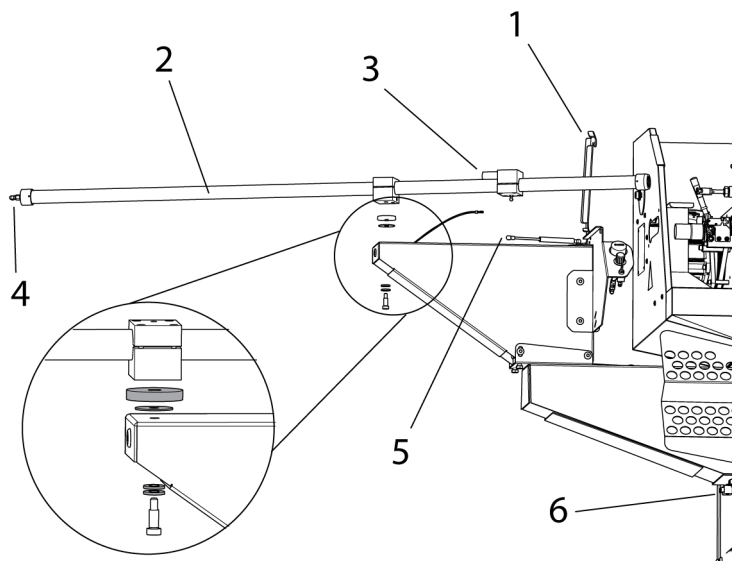

### To install the bar pusher:

1. Open the bar retainer [1] on the pusher mount.
2. Place the bar pusher tube [2] on the mount and install the hardware as illustrated.
3. Connect the wire to the EOB pressure switch [3]. Connect the 1/4" air hose to the end of the pusher tube [4].
4. Connect the strut [5] to the pusher tube.
5. Rotate the pusher tube [2] into the Run position and secure the bar retainer [1].

### 3.6.1 Bar Pusher Setup

**F3.5:** Bar Pusher Detail: [1] bar pusher tube, [2] end of bar (EOB) pressure switch, [3] support collar, [4] collet holder, [5] manual feed switch, [6] regulator, [7] air pressure gauge

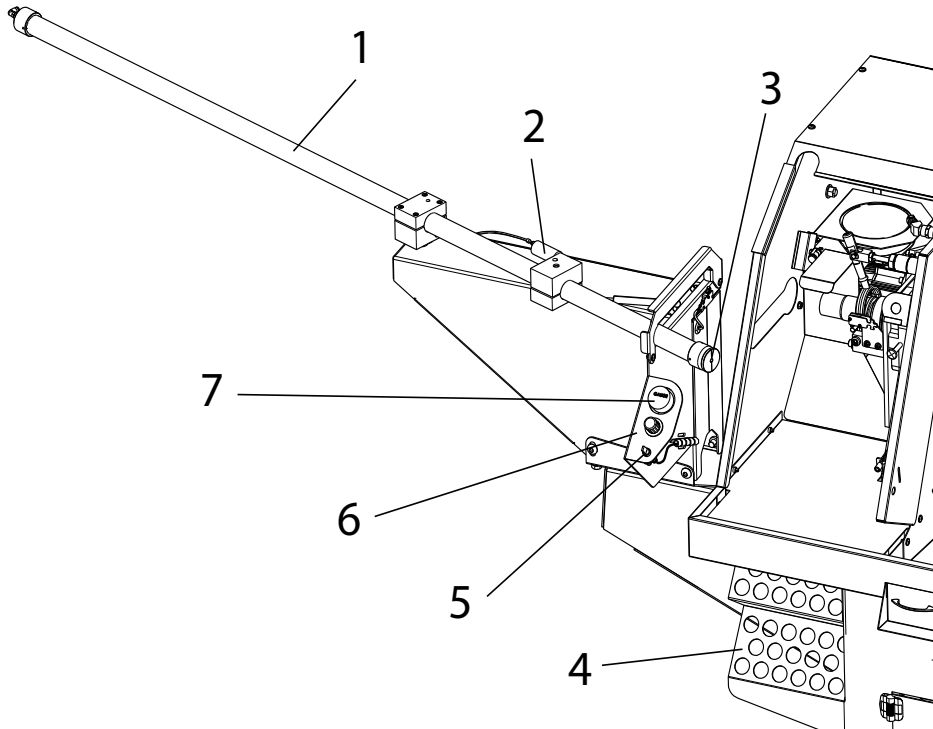

**NOTE:**

*The bar pusher can only be used with a collet. Do not use a chuck with the pusher option.*

**To set up the bar pusher:**

1. Open the operator door and rotate the pusher tube [1] to the load position.
2. Insert one piece of bar stock into the pusher tube [1] and install a two piece support collar [3] in the end of the pusher tube. The bar stock should have a slight chamfer on both ends to prevent binding and inconsistent push lengths.
3. Manually feed the bar using the manual feed switch [5]. Adjust the pusher air regulator [6] until the bar pushes out smoothly. Larger bar stock will require more air pressure. Stop feeding the bar when adjusted and push it back into the pusher tube.
4. Rotate the bar pusher tube [1] back to the run position. Manually feed the bar stock into the collet to the position where it will be cut off. Press the clamp button and check that the collet is adjusted correctly to properly clamp on the stock.

5. Select a tool with a flat edge that you want to use for the bar pusher stop. Handle jog the tool until the X and Z are even with the cutoff position.
6. Navigate to the PUSH TO STOP screen in the BARFEED page in IPS. Press **[F1]** to load the tool number, offset, and X and Z absolute position. Or the information can be entered manually by selecting each box using the cursor arrows, typing the appropriate values and press **[ENTER]**.

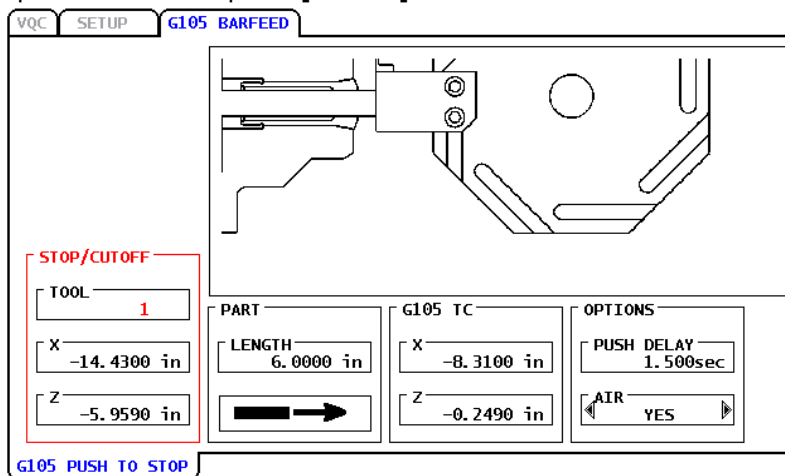

Index to Tool used as bar stop and jog to part cutoff position. Press F1 to record TOOL, X and Z position. Press CANCEL to exit current mode

## Bar Pusher Installation

---

7. Enter the part length, plus the cutoff distance. Press the down arrow, the control will

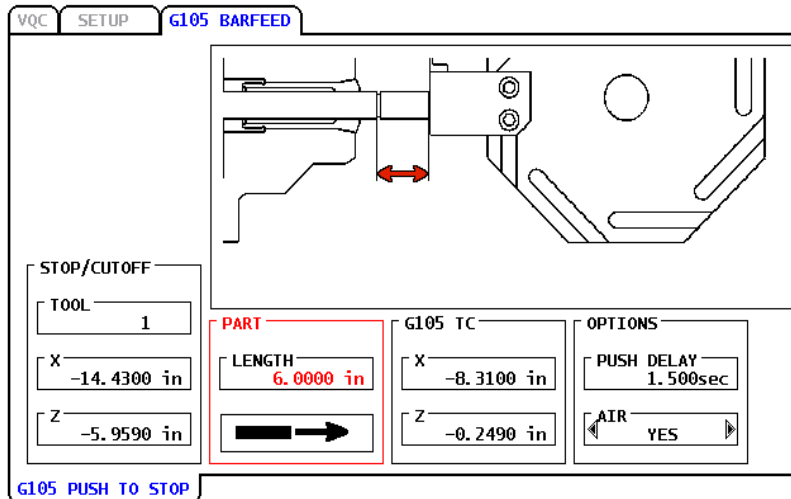

Enter length of part plus cutoff.

Press **CANCEL** to exit current mode

prompt you to close the door and press [**CYCLE START**] to push the bar to the part plus cutoff distance. The collet will open and the stock will feed. The Z axis will move into position and the collet will clamp.



8. Jog the turret to a safe tool change position and press F1. The machine will move to

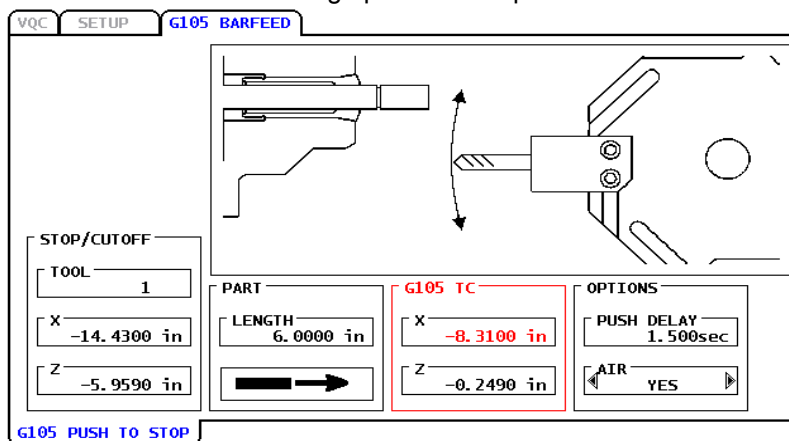

Jog to G105 TOOL CHANGE position.  
Press F1 to record.

Press **CANCEL** to exit current mode

this location to change tools.

9. Enter the time in seconds for the air push delay. Arrow right or left to select YES or

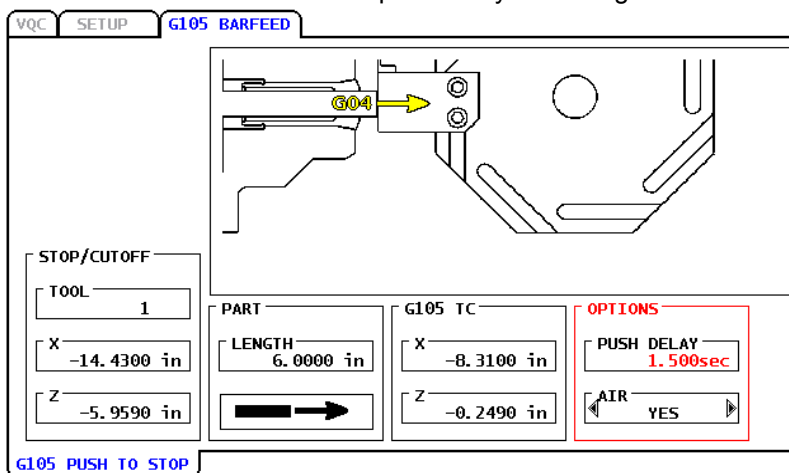

Time in seconds for air pressure to  
build up before pushing to part ZERO.

Press **CANCEL** to exit current mode

NO for Air Help on while running (normally set to YES). This feature, when enabled, will keep constant air pressure to the pusher to support the part. Smaller diameter material should use the Air Help to prevent bar whip while running.

### 3.6.2 Bar Pusher Operation

To operate the bar pusher:

```
MEM          000010      N00000000
Z-0.95 ;
N102 X0.4 ;
;
G00 G53 X-18.6 Z-3. ;
M01 ;
;
;
N2 ;
G00 G53 X-18.6 Z-3. ;
(PART-OFF) ;
T505 ;
G50 S4000 ;
S4000 M03 ;
G00 G54 X0.4 Z0.1 ;
M08 ;
G01 Z-0.87 F0.01 ;
M36 ;
G04 P1. ;
X-0.025 F0.002 ;
M37 ;
G00 X0.4 Z0.1 ;
;
G00 G53 X-18.6 Z-3. ;
M01 ;
;
;
G105 (BARFEED) ;
;
M30 ;
```

1. After the bar pusher has been set up, the push is activated by a G105 command in a program. Above is an example of a bar push after a part cutoff at the end of a program.
2. At the end of the pusher stroke the piston will push out the collars and activate the EOB pressure switch.

To re-load the bar pusher:

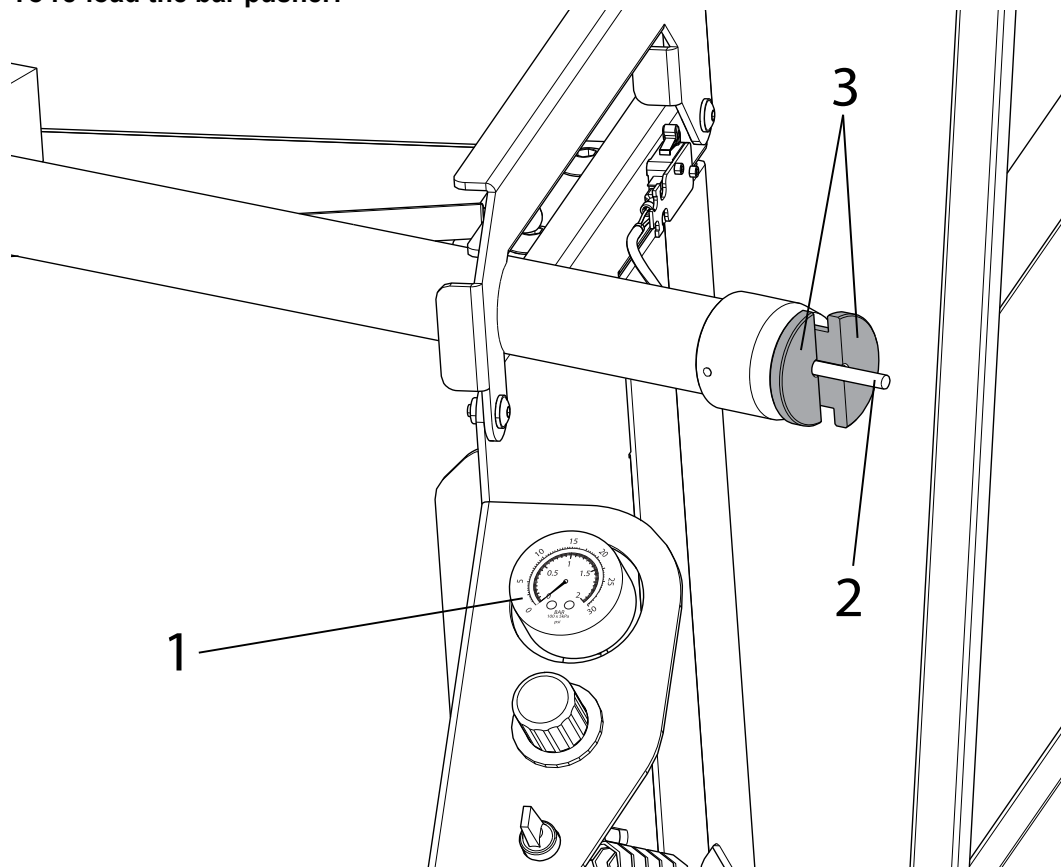

1. Check the bar pusher air pressure gauge [1], it should read 0 PSI/BAR. If not press **[RESET]** on the control.
2. With the operator door open, rotate the bar pusher tube to the load position.
3. Push one piece of bar stock [2] into the pusher tube. Install a support collar[3] around the stock in the end of the tube.
4. Rotate the bar pusher tube back into the run position. Activate the manual feed switch to feed the bar through the collet to the cutoff position. Clamp the collet. Press **[CYCLE START]** to continue running.

### 3.6.3 Bar Pusher Variables

These variables allows you to change the function of the control. When a program reads a system variable, it can modify its behavior based on the value in the variable.

#13100 = Part Push Length - A positive number changes the length the bar is pushed from the stop position.

#13115 = Turret Position of the Stop - This is the tool number for stop.

## Chucker Lathe Parts Catcher Setup

---

#13116 = X-axis Stop Position - The machine position with no work coordinate position applied.

#13117 = Z-axis Stop Position - The machine position with no work coordinate position applied.

#13118 = X-axis Tool Change Position - The machine position with now work coordinate position applied.

#13119 = Z-axis Tool Change Position - The machine position with now work coordinate position applied.

### 3.7 Chucker Lathe Parts Catcher Setup

**F3.6:** Chucker Lathe Parts Catcher: [1] part chute, [2] side-to-side adjustment clamp [3] parts tray,

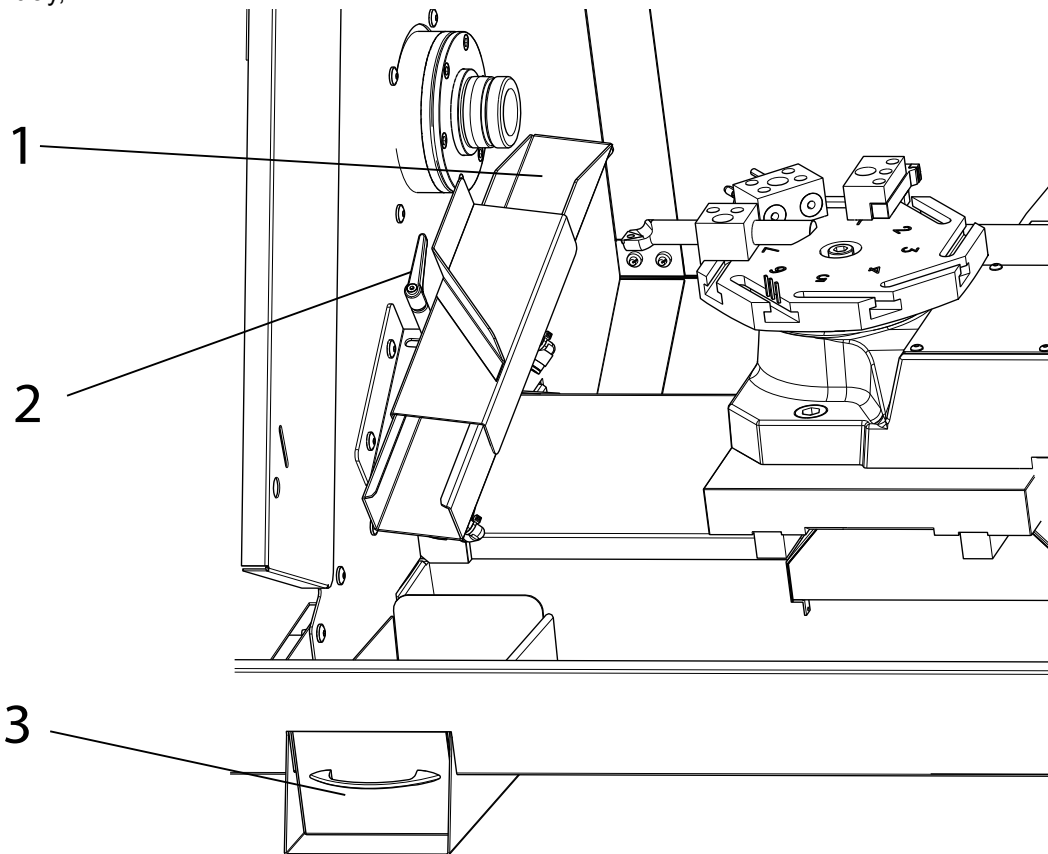

**To setup the parts catcher:**

1. Extend the stock out of the collet to the length of the finished part. Clamp the collet.
2. Command an **M36** to extend the part chute [1]. Loosen the adjustment clamp [2] and position the part chute as needed to catch the stock.
3. Press **[RESET]** to retract the parts chute.

### 3.7.1 Chucker Lathe Parts Catcher Operation

To operate the parts catcher:

1. The parts catcher is activated with an **M36** and is deactivated with an **M37**.
2. With the parts catcher setup, use an **M36** while the part is being cut off. This is an example program using the parts catcher during a part off.

ACTIVE PROGRAM - 000213

```
3  
;  
G00 G53 X-18.6 Z-3. ;  
M01 ;  
;  
;  
N2 ;  
G00 G53 X-18.6 Z-3. ;  
(PART OFF) ;  
T505 ;  
G50 S4000 ;  
S4000 M03 ;  
G00 G54 X0.4 Z0.1 ;  
M08 ;  
G01 Z-0.87 F0.01 ;  
M36 (PART CATCHER ON) ;  
G04 P1. ;  
X-0.025 F0.002 ;  
M37 (PART CATCHER OFF) ;  
G00 X0.4 Z0.1 ;  
;  
G00 G53 X-18.6 Z-3. ;  
M01 ;  
;  
;  
G105 (BAPUSH) ;  
;  
M30 ;
```

3. The cutoff parts will fall into the part tray. Pull out the tray and empty the parts as needed.

**Chucker Lathe Parts Catcher Setup**

---

# Chapter 4: Maintenance

## 4.1 Introduction

Regular maintenance is important to make sure that your machine has a long and productive life with minimal downtime. The most common maintenance tasks are simple and you can do them yourself. You can also ask your HFO about their comprehensive preventive maintenance program for complex maintenance tasks.

## 4.2 CL Lubrication

The linear guides and ball screws are automatically lubricated. The Chucker Lathe uses the Haas Liquid Grease system. Refill the liquid grease canister as needed.

Manually lubricate the bar pusher piston bi-monthly. Use the manual feed switch to push the piston out of the pusher tube. Wipe off the piston with a clean cloth. Apply a thick layer of grease (SHC460 or Mobil 1 Synthetic grease) to the piston and insert it into the pusher tube.

Lubricate the collet and spindle contact points with a light coat of molybdenum grease (Haas p/n 99-0007 or Mobil p/n CM-P) once a month. Make sure collets are in good condition and free from burrs. Following this procedure will extend the life of the spindle/collet, and help prevent sticking.

The current maintenance schedule and recommended type of lubricant is found in the Haas Resource Center on the Haas website. [diy.haascnc.com](http://diy.haascnc.com)

## 4.3 Troubleshooting

## Troubleshooting

| Symptom  | Possible Cause  | Corrective Action   |
|--|---|---|
| Part push-back   | Drawbar adjusted too loose                              | Re-adjust drawbar clamp position.   |
|  | Low air pressure will reduce the available clamp force. | Correct low pressure condition. Pressure should be above 80 psi. 100 psi is recommended.  |
|  | Excessive thrust loads                                  | Utilizing a collet stop will prevent push-back. The collet stop is not an option when using the bar pusher. Do not exceed 3,000 RPM.                                      |
|  | The collet is not correct for the material.             | Verify the collet is properly sized for the bar stock per the manufacturers recommendations. Use serrated collets when needed.  |
| Bar pusher vibration                                   | Excessive spindle speed.                                | Reduce spindle speed to 3,000 RPM or less. Larger bar stock is more susceptible to vibrations at speed.   |
|  | Bar stock chamfer not centered.                         | Center chamfer both ends of the bar stock.  |
|  | Bar pusher support collars are worn.                    | Replace worn out support collars.   |
|  | G105 bar pusher air option is off when it should be on. | Maintain air pressure with G105 Option Air "Yes" on the setup page.   |
|  | Bar pusher air pressure too high or too low.            | Adjust Bar pusher air pressure to meet bar stock size. Larger bars 15-20 psi, smaller bars 10-15 psi.   |
| Collet sticking and/or insufficient clamping pressure. | Excessive spindle/collet friction                       | Lubricate spindle and collet interface with a Molybdenum disulfide grease.  |
| Chips clogging coolant nozzles.                        | The coolant level is low.                               | Remove chips from nozzle and adjacent plumbing and always maintain a coolant level in the tank above 2". Coolant levels lower than 2" will allow chips to enter the pump. |
| Chips not flowing into the chip bin.                   | Build-up of stringy chips.                              | Review tooling and feedrates to eliminate stringy chips.  |



## 4.4 More Information Online

For updated and supplemental information, including tips, tricks, maintenance procedures, and more, visit the Haas Resource Center at [diy.HaasCNC.com](http://diy.HaasCNC.com). You can also scan the code below with your mobile device to go directly to the Resource Center:

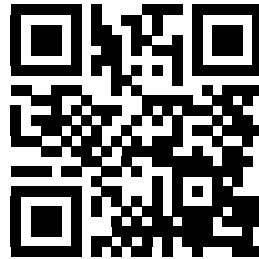



# Index

## A

|                   |        |
|-------------------|--------|
| Air Help .....    | 33     |
| ATT8 Turret ..... | 20, 27 |

## B

|                  |            |
|------------------|------------|
| Bar Pusher ..... | 19, 29, 30 |
| barstock         |            |
| safety and ..... | 6          |

## C

|                     |    |
|---------------------|----|
| chuck               |    |
| safety and .....    | 5  |
| Chucker Lathe ..... | 18 |
| Power On .....      | 21 |
| Crash Area .....    | 21 |

## M

|                   |    |
|-------------------|----|
| maintenance ..... | 39 |
| material          |    |
| fire risk .....   | 8  |

## O

|                  |   |
|------------------|---|
| operation        |   |
| unattended ..... | 8 |

## P

|                     |        |
|---------------------|--------|
| Parts Catcher ..... | 20, 36 |
|---------------------|--------|

## R

|                |    |
|----------------|----|
| Recovery ..... | 28 |
|----------------|----|

## S

|                              |    |
|------------------------------|----|
| safety                       |    |
| decals .....                 | 11 |
| door interlock .....         | 6  |
| during operation .....       | 4  |
| electrical .....             | 4  |
| glass window .....           | 6  |
| introduction .....           | 1  |
| maintenance .....            | 5  |
| part loading/unloading ..... | 5  |
| robot cells .....            | 10 |
| tool loading/unloading ..... | 5  |
| safety decals                |    |
| standard layout .....        | 11 |
| symbol reference .....       | 12 |
| safety information .....     | 16 |
| setup mode .....             | 8  |

## U

|                            |   |
|----------------------------|---|
| unattended operation ..... | 8 |
|----------------------------|---|

## W

|                  |   |
|------------------|---|
| workholding      |   |
| safety and ..... | 5 |
| workpiece        |   |
| safety .....     | 5 |

