

Wireless Intuitive Probing System

Operator's Manual

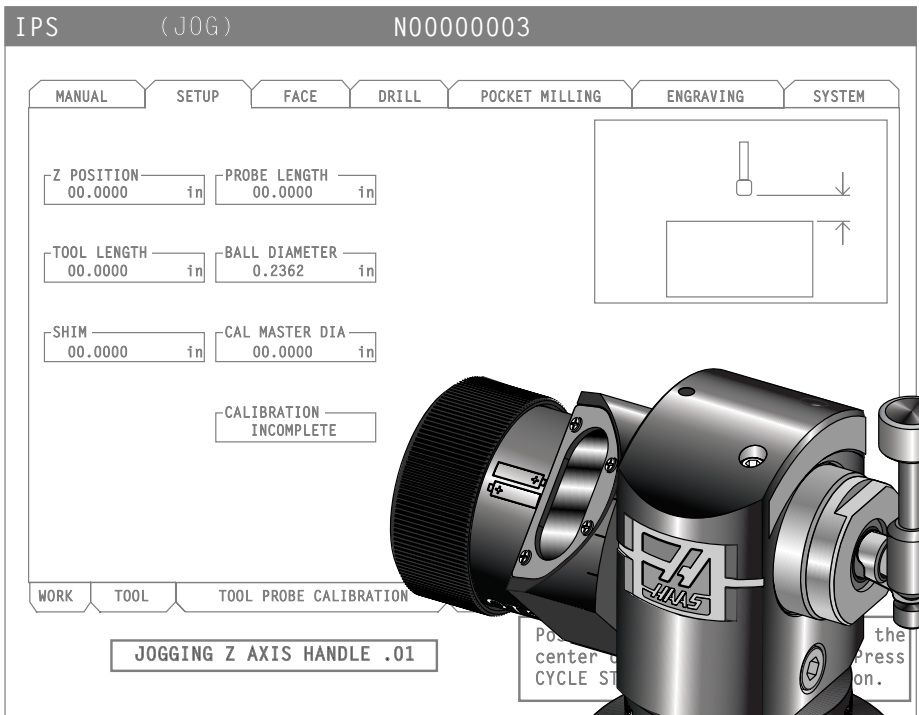



Contents

1. SET-UP AND OPERATION.....	2
ACTIVATING THE PROBE.....	3
CALIBRATION	3
OPERATION (TABBED MENUS).....	5
OPERATION (OFFSET TABLES).....	7
MAINTENANCE	10
BATTERY REPLACEMENT	10
REPLACEMENT PARTS.....	10
TROUBLESHOOTING	11
WIPS ALARM REFERENCE	11
2. INSTALLATION	12
WIPS SOFTWARE INSTALLATION	12
OMI BRACKET ASSEMBLY	12
RENISHAW SPINDLE PROBE IDENTIFICATION.....	13
RENISHAW TOOL SETTING PROBE INSTALLATION	13
VERTICAL MILLS.....	14
HORIZONTAL MILLS	19
TOOL SETTING PROBE ALIGNMENT AND INDICATION	23
ALIGNING THE WORK PROBE	24
ELECTRICAL INSTALLATION	26



1. SET-UP AND OPERATION

If WIPS came installed on your machine, remove the table probe shipping bracket. If you are installing WIPS, refer to the Installation section.

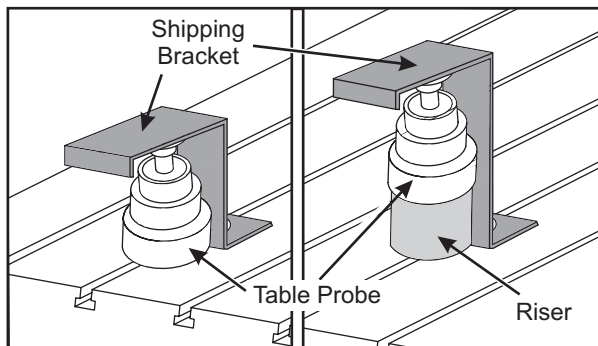
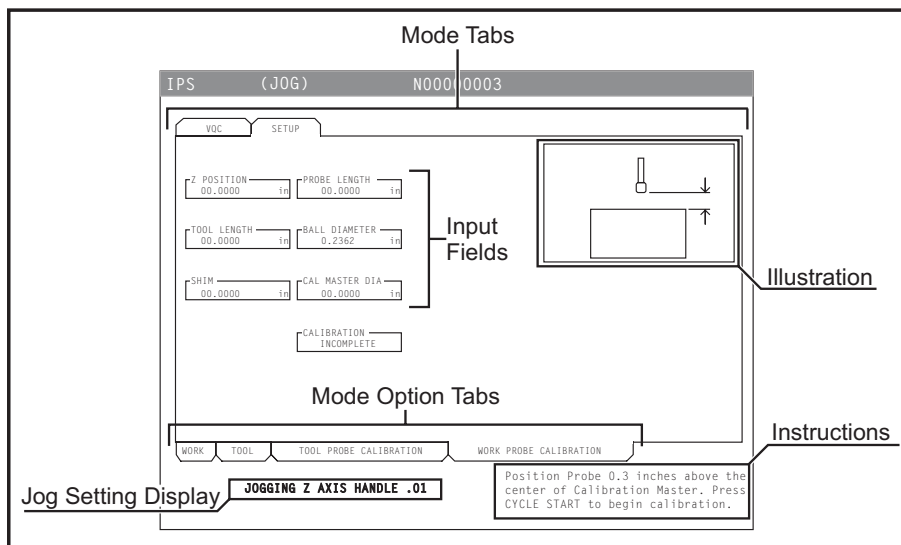

Table Probe Shipping Brackets

Basic Operation

To use WIPS, press MDI/DNC and then PROG/CONVRS. In Mill Software 16.04A and later, WIPS is also available in the offset tables. See the “Operation” sections for more details.



Sample WIPS Screen (Using Tabbed Menus)

Use the left/right arrow keys to navigate tabs. Press Write/Enter to select a tab, and Cancel to back out. For example, to return to handle jogging after using WIPS, press Cancel and then navigate to the “Setup” tab and press Write/Enter.

Within the IPS screen, use the arrow keys to navigate between entry fields.

For all functions, on-screen instructions appear to guide you through each step. Follow these instructions to complete tasks within IPS.



ACTIVATING THE PROBE

This procedure is used to verify that the spindle probe, table probe, OMI and the system's connection to the control are all functioning correctly.

1. In MDI mode, enter the following program to activate the table probe:
M59 P1133;
G04 P1.0;
M59 P1134;
2. Press Cycle Start.
3. After this program runs, gently tap the table probe with your finger. The control pendant should beep each time the probe is moved.
4. Press Reset to end activation.
5. In MDI mode, enter the following program and press Cycle Start to activate the spindle probe: M59 P1134;
6. After this program runs, gently tap the spindle probe with your finger. The control pendant should beep each time the probe is moved.
7. Press Reset to end activation.
8. If the probe fails to cause the pendant to beep, and the probe windows are properly aligned, first try replacing the batteries in the probe before attempting any other troubleshooting or service, as dead batteries are the most likely source of problems. See the following section for battery replacement instructions.

DO NOT use WIPS until the probes have been calibrated.

CALIBRATION

Tool Probe Calibration

Press MDI, then PRGRM CONVRS. Use left/right arrow keys to select the "Setup" tab and press Write/Enter. Use the left/right arrow keys to move to the Tool Probe Calibration tab and press Write/Enter. Step-by-step instructions can be found on the lower right hand side of the machine's screen.

1. Insert calibration bar into spindle. Any bar may be used to calibrate tool probe, if actual length and diameter are known.
2. Jog the Z-axis down to about 0.25" above table probe. Press F1 to record position.
3. Jog X and Y axis to a center position above table probe. Press F1 to record positions.
4. Press down arrow and enter the tool offset number or tool number. Press Write/Enter.
5. Press down arrow and enter tool length. Must be a positive number. Press Write/Enter.

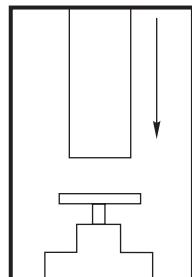



6. Press down arrow and enter tool diameter. Must be positive number. Press Write/Enter.

7. Press Cycle Start. The machine will execute an automatic calibration routine and display “COMPLETED” in the Calibration status box when the operation is finished.

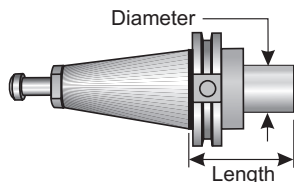

Calibration Bar

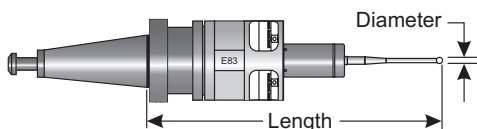

Work Probe

Work Probe Calibration

While in the Setup menu, use the right/left arrow keys to move to the Work Probe Calibration tab and press Write/Enter. Step-by-step instructions can be found on the lower right hand side of the machine's screen. The work probe is calibrated using an Inner Diameter (ID) calibration ring. First mount a calibration ring on the table (see figure on next page). A bored hole of known diameter in a fixture can also be used.

1. Put the calibration bar into the spindle (use “Tool Release” to change tools).
2. Place a shim of known thickness on the calibration ring and jog the Z-axis down until the bar just touches the shim. Press F1 to save the Z-axis position.
3. Enter the exact length of the calibration bar. Press Write/Enter.
4. Enter the thickness of the shim. Press Write/Enter.

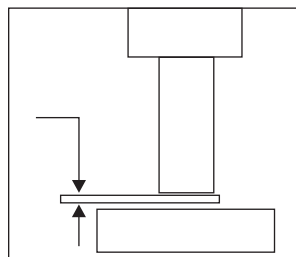

NOTE: The shim thickness can be left at zero.

Warning:

Change to work probe before continuing.

5. Put the work probe into the spindle (use “Tool Release” to change tools).
6. Enter the approximate length of the work probe. Press Write/Enter.
7. Enter the diameter of the ball on the work probe. Standard Renishaw probes use a 6 mm (0.2362”) ball. Press Write/Enter.

Note that any ring or bored hole can be used as long as the diameter is known.

8. Enter the inner diameter of the calibration ring. Press Write/Enter.

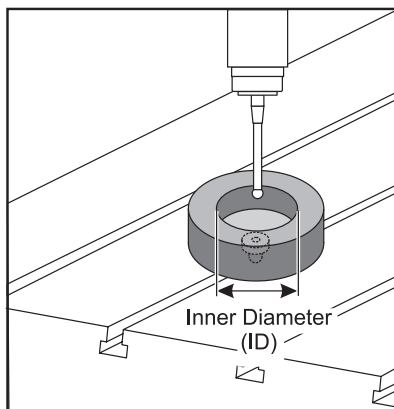



9. Handle jog the machine until the work probe tip is in the approximate center of the ring, and approximately 0.30" above the Z surface.

10. Press Cycle Start to start calibration. The calibration status box will indicate "COMPLETED" when the process is finished.

OPERATION (TABBED MENUS)

NOTE: Beginning with software version 16.04A, WIPS functions are also available using the Offsets tables. This is described in the next section.

Tool Setup

While in the Setup menu, use the right/left arrow keys to move to the "Tool" Mode Option Tab and press Write/Enter.

MANUAL	SETUP	FACE	DRILL	POCKET MILLING	ENGRAVING	VQC
Press ATC FWD or ATC REV to change the tool displayed. Press NEXT TOOL to change the tool in spindle. Press F2 to set tool dimensions with probe.		Tool in Spindle: 1 Tool Displayed: 1 Tool Type DRILL 		Tool Diameter 0.0000 in	TPI 0.0000	
				Point OFF	Z Length 0.0000 in	
				Flutes 2	Z Wear 0.0000 in	
				Spindle RPM 0	Tool Wear 0.0000 in	
		Tool Material User		Feedrate 0.0000 in	Coolant Pos 0	
WORK	TOOL	TOOL PROBE CALIBRATION		WORK PROBE CALIBRATION		

1. Use the Right/Left arrows to select the tool type: Drill, Tap, Shell Mill, End Mill, or Center Drill. Press Write/Enter.

NOTE: Alternate for Tool Offset: Use the Up/Down arrows to select the Tool Offset number box. Enter the Offset number and press Write/Enter. Check that the offset is referenced correctly in the part program.

2. Press F2 to set tool dimensions using a probe.

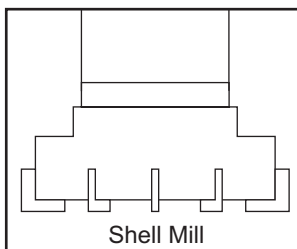
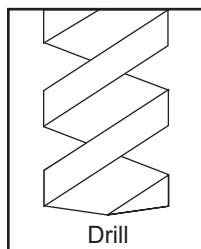

- When F2 is pressed a Tool Dimensions screen pops up.
- Enter the approximate tool dimensions.
- Press Cycle Start to automatically set tool length and diameter.



NOTE: To measure tool length only, leave the value for Z at zero. Tool diameters will not be measured. However, diameter values must be entered to measure length on milling cutters.

3. To advance to the next tool in the tool changer, press “Next Tool”.

NOTE: Tools can be loaded into the spindle while in Tool Setup by pressing “Tool Release”.

4. Successive tools can be set up with the probe by repeating Steps 1 to 3.

Work Setup

While in the Setup menu, use the right/left arrow keys to move to the Work tab and press Write/Enter. This menu allows the user to select the desired surface to be probed. Step-by-step instructions can be found on the lower right hand side of the machine’s screen.

1. Use Up/Down arrows to change Work Coordinate System. Press Write/Enter.

MANUAL SETUP FACE DRILL POCKET MILLING ENGRAVING VQC

Wrk Zero Ofst
54

Press F2 to set offsets using probe.

X Offset 0.

Y Offset 0.

Z Offset 0.

A Offset Disabled

B Offset Disabled

Work Material NO MATERIAL SELECTED

WORK TOOL TOOL PROBE CALIBRATION WORK PROBE CALIBRATION

2. Press F2 to set offsets using a probe.

3. A pop-up screen is displayed. Use the Right/Left arrows to scroll through the probing functions. Select a function by pressing Write/Enter.

4. Follow the directions on the selected pop-up screen, then press Cycle Start. Note that user-entered increment measurements are sign dependent; to command the probe down to your specified Z increment, the value you enter must be negative.

5. **NOTE:** If incremental Z measurement is left at zero for most work probing routines that use it (Boss, Rectangular Block, Web X, Web Y, Inside Corner, Outside Corner), a default value is used. The probe first moves down to find the material surface, then moves out to prescribed X and Y increments, probing the corner at a default depth (around 1/4” (6mm)). If no surface is found within a short distance from the probe’s starting location, the operation alarms out. If the workpiece has feature such as a chamfer or radius, enter a Z increment large enough for probing the surface below the feature. The Z increment begins at the starting location of probe, not the surface of the workpiece.

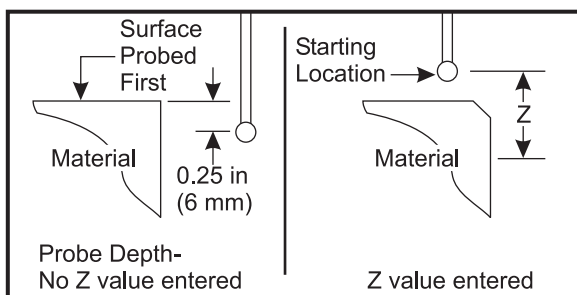

For probing routines more advanced than those available in WIPS, consult the probe manufacturer's documentation or website.

OPERATION (OFFSET TABLES)

This operation mode is available in mill software version 16.04A and later.

Tool Setup

1. Press MDI, then OFFSET until the tool offset table is active.
2. Use the left/right cursor arrow keys to navigate columns on the table. Moving past the extreme left or right column of a table moves to the next table. Three tables are available: Tool Offset, Tool Info, and Probing. The display pane directly underneath the tool offset tables will display relevant help information as the cursor is moved.

<< TOOL INFO		PROBING			TOOL OFFSET >>	
TOOL	APPROXIMATE LENGTH	APPROXIMATE DIAMETER	EDGE MEASURE HEIGHT	TOOL TOLERANCE	TOOL PROBE TYPE	
1	1.3750	0.2500	0.2500	0.	3-LEN & DIA	
2	1.7500	0.3750	0.2500	0.0500	1-L ROTATING	
3	0.	0.	0.	0.	0-NONE	
4	0.	0.	0.	0.	0-NONE	
5	0.	0.	0.	0.	0-NONE	
6	0.	0.	0.	0.	0-NONE	
7	0.	0.	0.	0.	0-NONE	
8	0.	0.	0.	0.	0-NONE	
9	0.	0.	0.	0.	0-NONE	

ENTER A VALUE. PRESS [WRITE] TO ADD OR [F1] TO SET THE VALUE.

<p>TOOL PROBE HELP</p> <p>Enter the approximate length of the tool to be measured.</p> <p>(Enter a positive number only).</p> <p>Press the [TOOL OFFSET MEASUR] key to start the Automatic Probing Options.</p>	<p>Tool Type: DRILL</p>
---	-------------------------

Probing Tool Offsets Example Screen

3. Set up each tool to be probed in the table as follows:
 - a. In the "Tool Info" table, enter the tool type.
 - b. In the "Probing" table, enter the approximate length of the tool. If diameter is to be probed as well, enter an approximate value for the tool diam-



eter, and the distance from the tool tip where diameter will be measured. Enter a wear tolerance value in the appropriate column (optional).

c. Select the probe type. If enough information is entered to allow WIPS to successfully perform the selected probe operation on the tool, this value will appear with a green background. If the background is red or white, the probe operation will fail for that tool. The comment “Tool # does not have all of its inputs” will appear in the program generated.

4. Press the TOOL OFFSET MEASUR key. Select one of the probe options and press Cycle Start to generate the program in MDI and run it, or press INSERT to copy the program to the clipboard.

Work Setup

1. Press MDI, then OFFSET until the Work Offset table is active.

2. Use the left/right cursor arrow keys to navigate columns on the table. Moving past the extreme left or right column of a table moves to the next table. This mode features two tables: “Axes Info” and “Work Probe”. Press left or right until the “Work Probe” table is active.

0-NONE						
1-BORE	2-BOSS	3-RECT POCKET	4-RECT BLOCK	5-WEB X AXIS	6-POCKET X AXIS	
7-WEB Y AXIS	8-POCKET Y AXIS	9-OUTER CORNER	10-INNER CORNER	11-SINGL SURFACE	12-VISE CORNER	

<< AXES INFO		WORK ZERO OFFSET	AXES INFO >>
G CODE	PROBE ACTION	WORK PROBE INPUTS	
G52	DISABLED	Corner	0
G54	INNER CORNER	Incremental Z	0.
G55	NONE	Incremental X	0.
G56	NONE	Incremental Y	0.
G57	NONE		
G58	NONE		
G59	NONE		
G154 P1	NONE		
G154 P2	NONE		
G154 P3	NONE		

Work Probe Setup Example Screen

3. Use the up down cursor arrow keys to select a work offset value. Enter the number from the table above corresponding to the probing operation to be performed and press WRITE/ENTER.

4. Press the right cursor arrow key to enter work probe inputs. Help information appears in the pane above the work offset table for the selected operation.

5. Position the probe as directed and fill in the inputs as needed. Cycle Start to generate the program in MDI and run it, or press INSERT to copy the program to the clipboard.

6. If incremental Z measurement is left at zero for most work probing routines that use it (Boss, Rectangular Block, Web X, Web Y, Inside Corner, Outside



Corner), a default value is used, The probe first moves down to find the material surface, then moves out to the prescribed X and Y increments, probing the corner at a default depth (around 1/4" (6mm)). If no surface is found within a short distance from the probe's starting location, the operation alarms out. If the workpiece has feature such as a chamfer or radius, enter a Z increment large enough for probing the surface below the feature. The Z increment begins at the starting location of probe, not the surface of the workpiece.

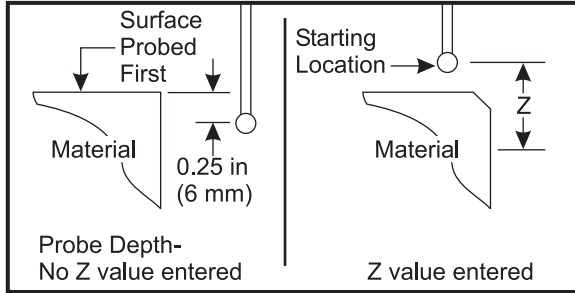



MAINTENANCE

BATTERY REPLACEMENT

Batteries for Probing Options

Haas Part #
99-43553

Renishaw OMP40 Spindle Probe 3.6V Lithium 1/2 AA
 OTS Table Probe

Probe Battery Replacement

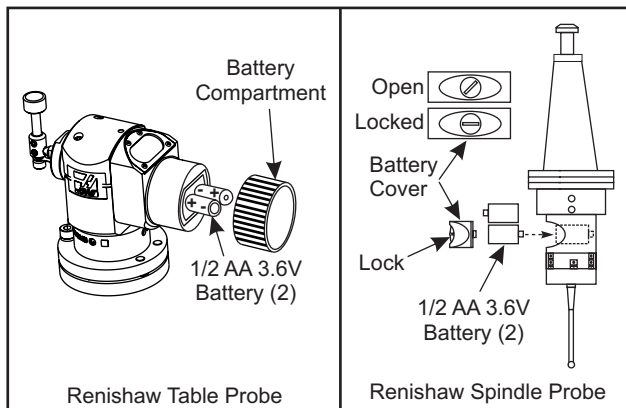

Renishaw Spindle Probe - Renishaw Spindle Probe contains two 3.6V batteries.

Use a coin to unlock and remove the battery cover located on the side of the probe. Remove both 3.6V batteries, insert new ones and replace the battery cover.

Renishaw Table Probe - Renishaw Table Probe contains two 1/2 AA 3.6V batteries.

Unscrew the battery cover/holder from the battery compartment located on the side of the probe. Remove both 3.6V batteries, insert new ones and replace cover/holder.

REPLACEMENT PARTS

Renishaw

- 60-0026 - Ceramic Stylus (Spindle Probe)
- 60-0028 - Disk Stylus (Table Probe)
- 60-0029 - Stylus Holder (Table Probe)
- 60-0030 - Link Break Protect (Table Probe)
- 60-0034 - Extension (Table Probe)



TROUBLESHOOTING

Most communications problems in the WIPS system are caused by either dead/low batteries, or an accumulation of chips on probe windows. If chips tend to collect on the table probe window, consider programming a coolant washdown of the probe before carrying out tool probe operations. For assistance with this, please contact your dealer.

If any component of the WIPS system is moved, recheck alignment and recalibrate before using the system.

WIPS ALARM REFERENCE

Alarm	Alarm Message	Notes	Action
1001	Message varies	Out of tolerance failure	Reset to continue.
1082	Tool Out of Range	This alarm occurs if cutter size exceeds maximum cutter diameter size set in variable #590 (582 + 8).	Check Approximate Diameter value entered on the IPS page.
1086	Path Obstructed	Protected Positioning Cycle only.	Clear the obstruction and start again from a safe position.
1088	No Feed Rate	Protected Positioning Cycle only.	Insert the F__ code input and start again from a safe position.
1089	No Tool Length Active	G43 or G44 must be active before the cycle is called.	Edit the program and start again from a safe position.
1091	Format Error	Inputs are mixed, missing, or incorrectly formatted.	Edit the program and start again from a safe position.
1092	Probe Open	This alarm occurs if the probe is already triggered before a move.	Clear fault and start from safe start position. Stylus may be in contact with surface, or probe failed to reset. Possible swarf trapped around probe eyelid.
1093	Probe Fail	This alarm occurs if the probe did not trigger during the move.	Edit program and start from safe start position. Surface was not found or the probe has failed.
1099	Broken Tool	This alarm occurs if a tool is out of tolerance and the Mm input is not used.	Replace defective tool and establish correct tool offset value.
1101	Probe Startup Failure	During probe start-up, the spindle must reach a speed of 500 RPM.	Check that the spindle speed override is not active. Possible faulty probe.



2. INSTALLATION

NOTE: For VF, EC, GR, MDC and Super Mini Mill machines, I/O board 3080U or 3083U or later is required to install WIPS. For Mini Mills and all TM machines, I/O board 3082V or later is required.

WIPS SOFTWARE INSTALLATION

WIPS requires software versions M14.05A (Coldfire I / II processor and 10" LCD), or M15.04E (Coldfire II processor and 15" LCD) or later. Install WIPS macros into program memory. Contact your dealer to obtain latest WIPS macros. Six parameters must be set:

Parameter 57, bit 17 "Enable Rot & Scaling" set to "1"

Parameter 57, bit 21 "M19 Spindle Orientation" set to "1"

Parameter 57, bit 22 "Enable Macro" set to "1"

Parameter 57, bit 23 "Invert Skip" set to "0" (Renishaw)

Parameter 315, bit 31 "Intuitive Programming System" set to "1" (16.03 and earlier)

Parameter 732 "IPS Probe" set to "2"

OMI BRACKET ASSEMBLY

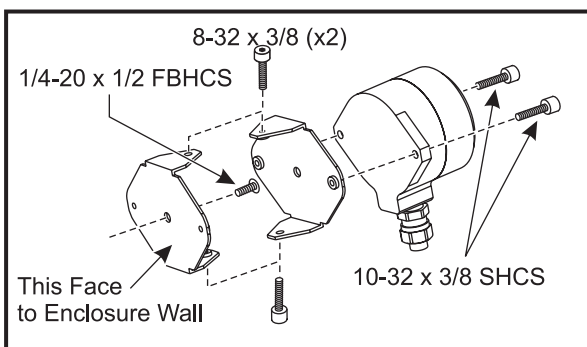

1. Secure one bracket to the OMI using two 10-32 x 3/8 SHCS.
2. Secure the other bracket to the machine enclosure wall using one 1/4-20 x 1/2 FBHCS.
3. Attach the wall bracket to the OMI/bracket assembly using two 8-32 x 3/8 SHCS.



RENISHAW SPINDLE PROBE IDENTIFICATION

The OMP40 for WIPS will not work with VQCPS.

The OMP40 for VQCPS will not work with WIPS.

The two probes can be differentiated by the Haas logo on the probe, as shown:

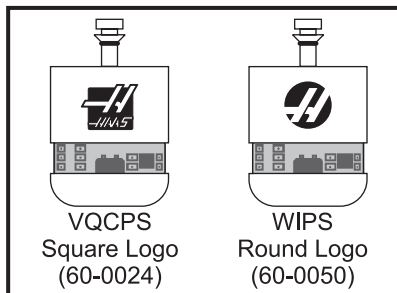

RENISHAW TOOL SETTING PROBE INSTALLATION

1. Select a location on the table for the tool probe. For machines using a fixed toolsetting probe arm (EC-400/500/630, MDC-500), skip this step and see the mounting instructions for these machines.

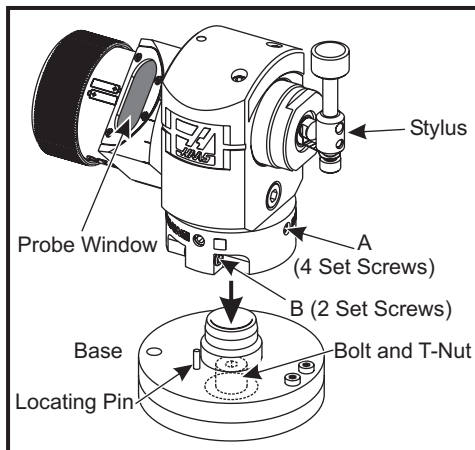

2. Separate the base from the body by loosening the four set screws (A) around the bottom of the probe assembly. Also loosen the two set screws (B).

3. Fit a socket head cap screw and appropriate T-nut for your machine table through the base and tighten to secure the base to the mount location. Make sure the locating pin is oriented so that the probe will face the OMI when installed.

4. Refit the probe to the base and tighten all screws to secure it.



VERTICAL MILLS

Mount the table probe anywhere on the table, using a T-nut and 1/2-13x1 SHCS (on a metric table use an M12X1.75 T-nut and M12X30mm SHCS). The recommended location is on the right side of the table, away from the tool changer. This position also allows the probe window to face away from flying chips, prolonging probe life. The spindle must have enough travel to reach all four sides of the probe stylus. Allow 2" of travel on all four sides of the probe stylus, for calibration.

Renishaw probes measure tool diameters using (+Y) and (-Y) travel. Ensure that table probe mounting allows enough Y-travel for tool diameter measurement; for example, allow at least 5" of total travel around the table probe to measure tool diameters up to 6". Allow 3" of travel to measure tool diameters up to 3".

NOTE: The VF-10 and VF-11 must have the probe placed no closer to the spindle head than the second table slot, to avoid collision with the spindle head.

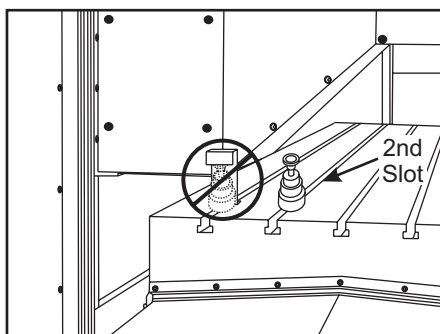

VF-10/VF-11 Spindle Head Crash

Using Risers

Risers may be required to give the table probe the proper height to operate correctly. A 2 1/2" riser is always included with a VF-5 or a VF-3YT/50, and may be purchased separately for other machines. A taller riser (10 1/4") is available for the VF-6 or VF-8, with the EC6 option or VF-11 with EC11 option having an 8" extended Z-axis.

NOTE: When using a riser with the EC11 option, place the probe no closer to the spindle head than the third table slot, to avoid spindle head collision.

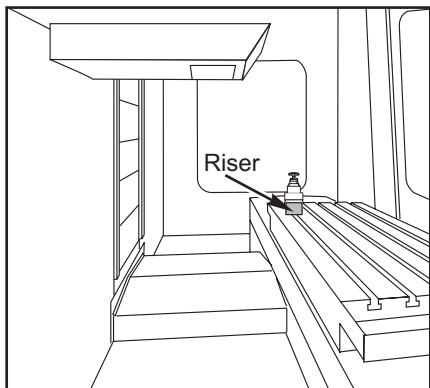

VF-3YT/50 and VF-5

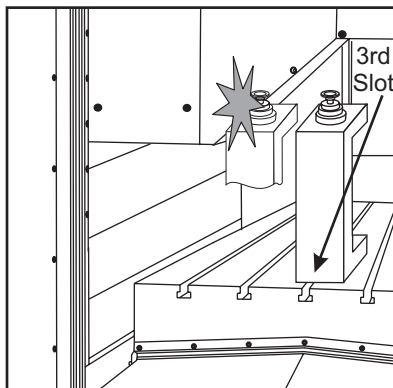

VF-11 w/EC11 Option

Pallet Changing Vertical Mills

The tool setting probe is mounted to the table using a special bracket that positions the probe. This bracket is mounted to the table using the existing bolt holes as shown in the following figures.

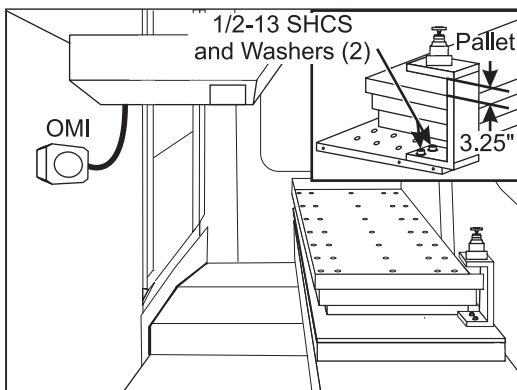

APC/APC QUAD Pallet Changer Probe Configuration

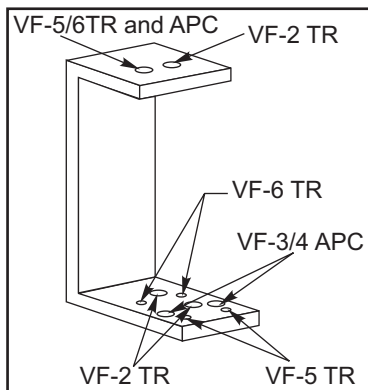

APC/APC QUAD Mounting Bracket

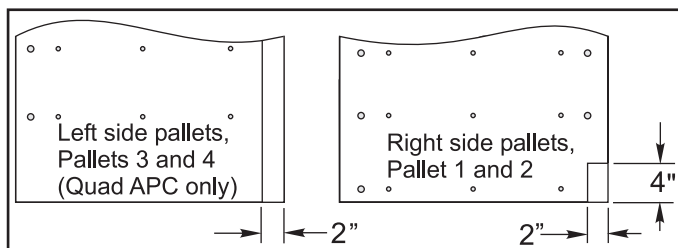

Warning: The probe mounting bracket is over the top of the pallet. Fixtures or parts taller than 3.25" passing under the probe will collide with the probe mounting bracket



Trunnion Mills

The tool setting probe is mounted to the table using a special bracket that positions the probe. This bracket is mounted to the table using the existing bolt holes as shown in the following figures.

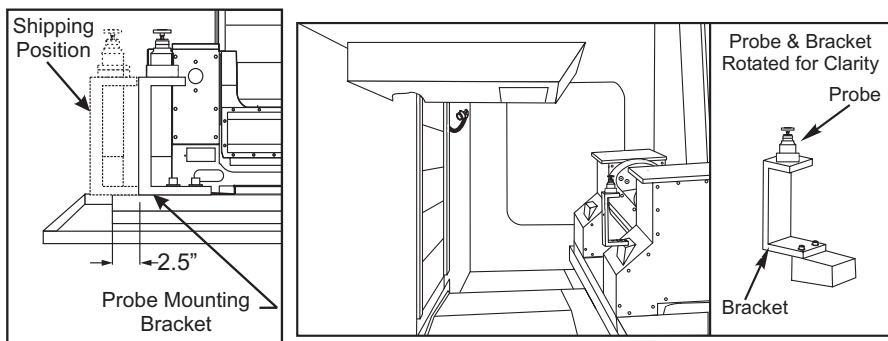

VF-2TR Probe Mounting

VF-5TR Probe Mounting

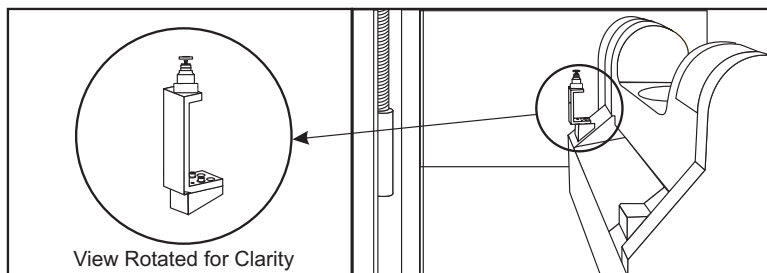

VF-6TR Probe Mounting

Gantry Mills (GR-510 / 512 and GR-710 / 712 Only)

The table probe can be placed anywhere on the table as long as it is within machine travel, clear of the tool changer and the probe window can be aimed at the OMI when the probe is under the spindle. Allow sufficient travel to measure larger diameter tools.

OMI Installation

1. Jog the X-axis to the farthest point from the control pendant.
2. Mount one of the brackets with a 1/4-20 SHCS to the underside of the bridge. It may be necessary to drill and tap one 1/4-20 x 1/2" hole; see the following figure for location. Align the bracket as shown; the alignment is important. Fasten the OMI unit to the other bracket using two (2) 10-32 x 3/8 SHCS.
3. Mount the OMI/bracket to the column bracket using two (2) 10-32 x 3/8 SHCS. Angle the OMI unit so that the two brackets are almost touching, as shown in the figure.

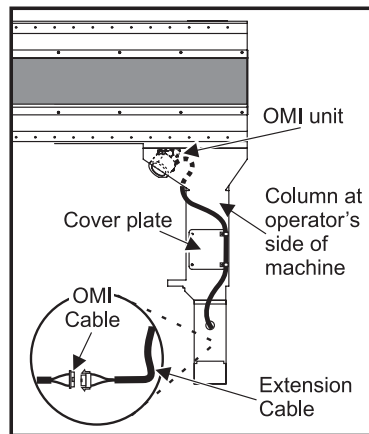
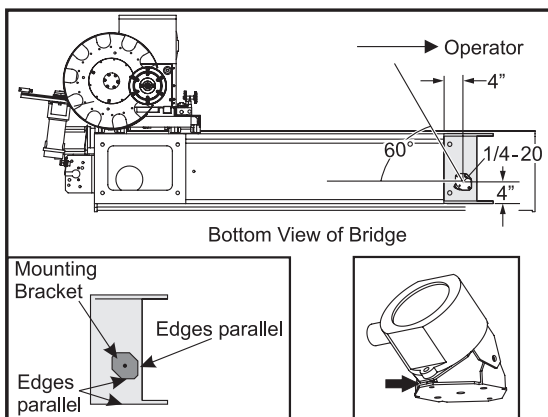

4. Route the extension cable through the cable carrier and along the sheet metal shelf, following other cables and tubing to the control cabinet. The cable is positioned in the upper section of the X-axis cable carrier. **Note that on machines built before July 1, 2003, replace the cable carrier with one equipped with separators.** Connect the end of the extension cable labeled "TO 33-0615" to the end of the 33-0615 cable labeled "TO OMI CONN" inside the control cabinet (see the Electrical Connections section).

5. Route the OMI cable through the hole in the column. Connect the OMI cable to the end of the extension cable labeled "TO 32-0750". Fasten the cable to the cover plate with two (2) cable clamps. Use the existing screws on the cover plate. Pull the excess cable into the bridge and coil it up inside.

Refer to the "Alignment" section for probe and OMI aiming instructions.

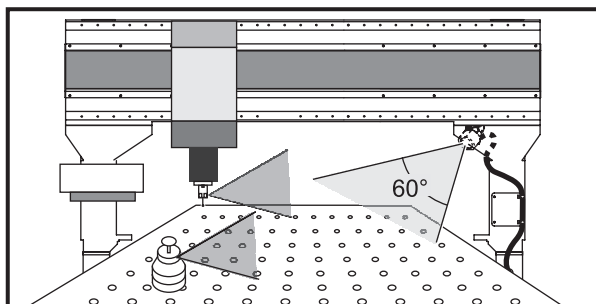

The OMI detects probe signals within a 60° "cone" from the OMI window. Position the OMI such that it receives a signal within this range over the entire Y/Z travel range. Check tool setter activation. It is easier to locate the toolsetter within activation range if it is positioned on the tool changer side of the machine.



MDC-500 OMI Mounting

1. Mount the OMI unit on the sheet metal as shown, using the provided pemnut and a FBHCS 1/4-20 x 1/2.
2. Remove the plug in the sheet metal, install the grommet (must be cut) into the 1" hole, connect an extension to the OMI cable, and route the cable through the sheet metal to the control cabinet.
3. Route the OMI cable behind the SMTC mount, into the base cable tray, then through the access holes in the control panel.

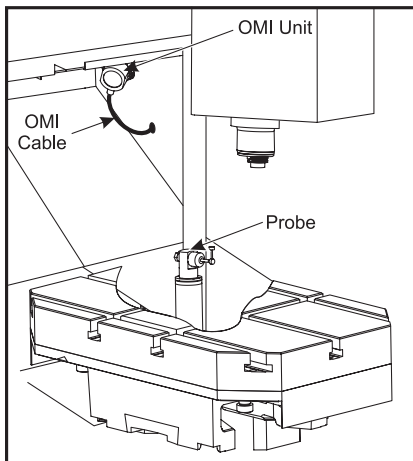

Tool Setting Probe

1. Install bracket and post onto rotary body and torque fasteners.
2. Install tool setting probe to the bracket using a SHCS 1/2-13 x 1" and align the probe window with the OMI.

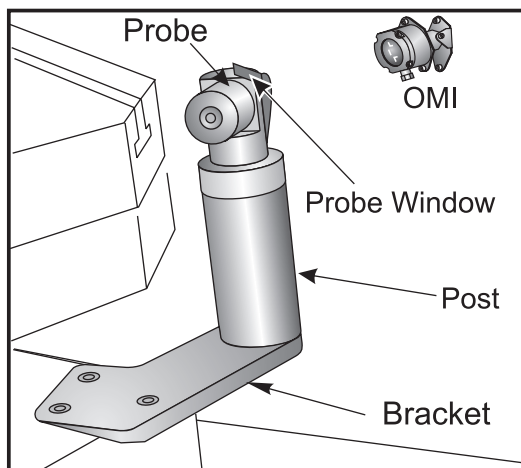

MDC-500 Tool Setting Probe Bracket



HORIZONTAL MILLS

EC-400/500

The tool setting probe is installed on a mounting arm that is secured to the rotary body. For EC-400/500 machines, this arm is secured to a mounting block (P/N 20-2331 for EC-400, 20-3218 for EC-500) installed to the operator side of the rotary body. The probe assembly also incorporates a chip shield for these machines. See the following illustration.

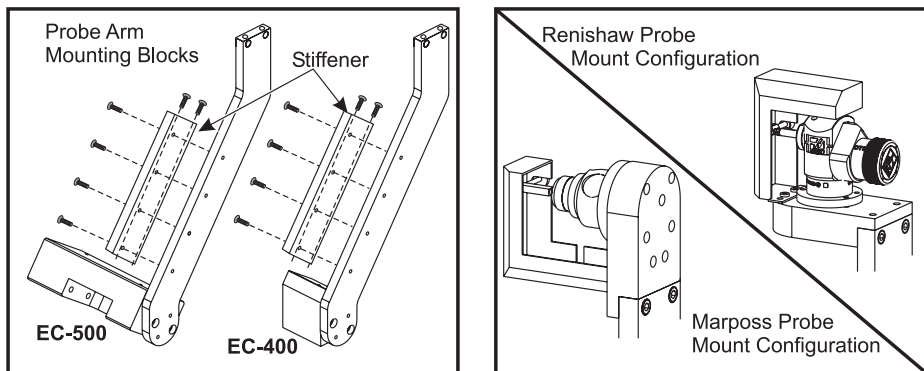

Tool Setting Probe Installation

1. Secure probe arm and mounting block to rotary body. Install stiffener to arm. Install probe mount block to end of arm in appropriate configuration for your probe.
2. Install the probe on the probe mount block.
3. Indicate-in the probe stylus within .001" (0.03 mm)
4. Attach the chip shield.

OMI Mounting

1. Mount OMI unit on top cover. Attach bracket to top cover. Mount OMI to other bracket using (2) 10-32 x 3/8 bolts. Fasten OMI/bracket to bracket using (2) 8-32 x 3/8 bolts.

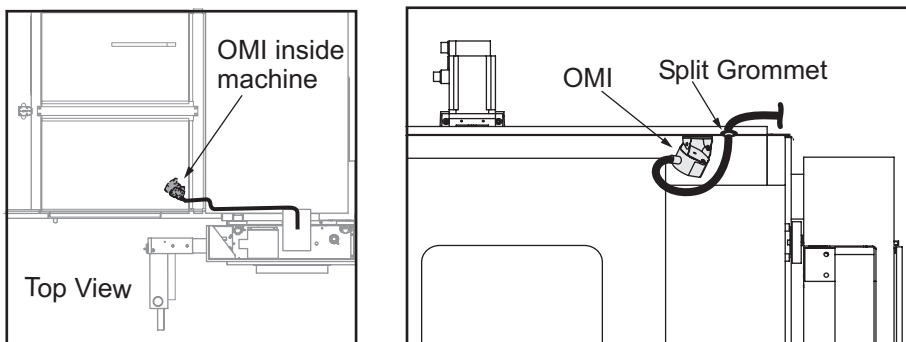



2. Remove the plug in the top cover and route the cable through the top cover to the control cabinet. See the Electrical Connections section for the location of the OMI cable socket. Install the grommet (it must be cut) into the hole on the top cover.
3. Route the cable into the top of the control cabinet. Position the conduit so that it ends inside the j-box. Secure the other cables on top of the machine using cable ties.

EC-630

Tool Setting Probe Installation

1. Secure probe arm to the tool changer side of the rotary body as shown in the illustration.
2. Install the tool setting probe onto the probe arm using a 1/2-13 x 1 SHCS.
3. Indicate-in the stylus within 0.001" (0.03 mm)
4. Attach the chip shield using two 1/4-20 BHCS as shown.

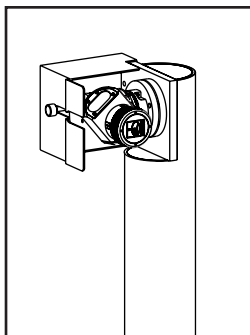
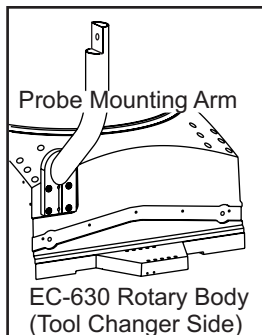

OMI Installation

NOTE: This installation requires an extension cable.

1. Mount OMI above and to right of tool changer door. Use existing FBHCS 1/4-20 x 1/2, second screw from top. Attach bracket to enclosure wall and mount OMI to other bracket using (2) 10-32 x 3/8 bolts. Fasten OMI/bracket to bracket using (2) 8-32 x 3/8 bolts.

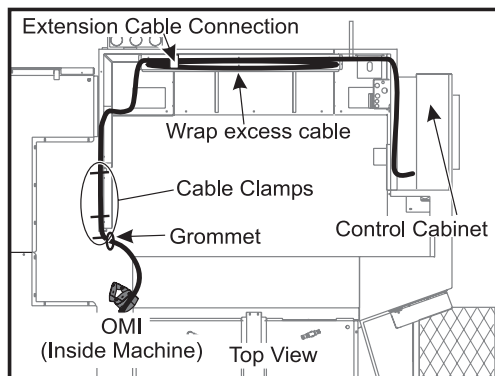
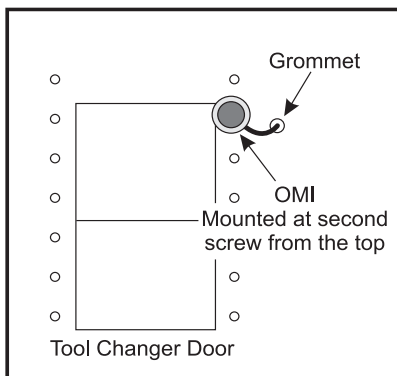



2. Remove the plug in the sheet metal and install the cut grommet into the hole. Route the OMI cable through this hole and along the machine enclosure next to the tool changer, securing with cable clamps. Route the cable to the cable tray at the machine rear and connect the extension cable. Continue to route the cable around the rear of the machine, along the cable tray and follow the existing wiring around the counterbalance tank and to the control cabinet. Lay excess cable along the cable tray at the rear of the machine and secure with cable ties. See “Electrical Installation” to continue.

3. Aim the OMI halfway between the tool setter and spindle location. When installation is complete, verify probe activation.

EC-1600/2000/3000

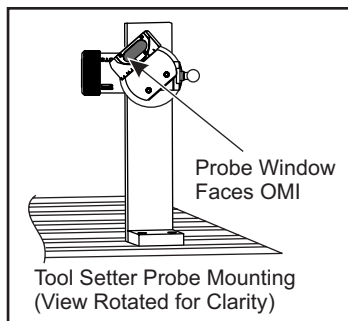
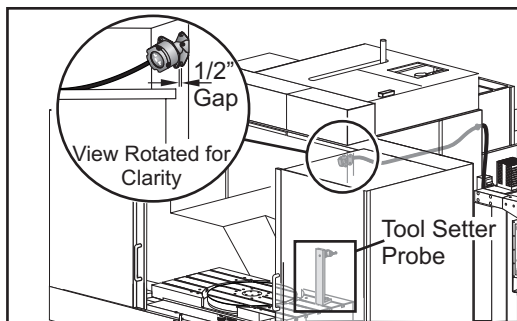

OMI Mounting

1. Attach one of the brackets into the existing hole in the sheet metal using one FBHCS 1/4-20 x 1/2 and one nut 1/4-20 hex flange. Mount the OMI to the other bracket using (2) 10-32 x 3/8 bolts. Fasten the OMI and bracket to the bracket on the back panel using (2) 8-32 x 3/8 bolts. Set the OMI bracket angle at a 1 1/2” from the wall bracket.

2. Route cable using clamps and existing screws. Route cable toward back of machine and to top of the control cabinet. The conduit jacket should be positioned so it ends inside the J-box on top of the control cabinet. Refer to Electrical Connections for final connection.

Tool Setting Probe

1. Tool setting probe for the EC-1600/2000/3000 is mounted to table using specific bracket that positions the probe toward the front right of the table. This bracket is mounted to the table using the four (4) SCHS 1/2-13 x 1 1/2 and T-slot nuts. A customer-supplied bracket can be used for alternate toolsetter locations. Use 1/2-13 SHCS x 1” or M12 x 30 SHCS.

2. Mount table probe to probe mounting bracket. See probe alignment section for proper alignment instructions.



ES-5

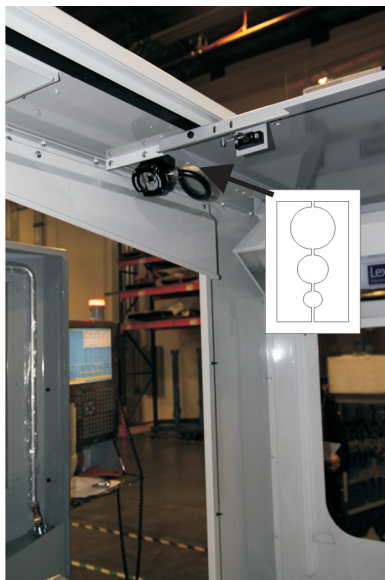

OMI Mounting

1. Attach one of the brackets into the existing pemnut holes in the roof sheet metal. Mount the OMI to the other bracket using (2) 10-32 x 3/8 bolts. Fasten the OMI and bracket to the bracket on the roof using (2) 8-32 x 3/8 bolts. Set the OMI bracket angle.

2. Route cable using through the hole in the roof. Clamp the cable as it exits the roof using a plastic split grommet. Continue the cable toward back of machine to the top of the control cabinet. The conduit jacket should be positioned so it ends inside the J-box on top of the control cabinet. Refer to Electrical Connections for final connection.

Tool Setting Probe

1. Tool setting probe is mounted to table via a bracket. This bracket is mounted to the table using the four (4) SHCS 1/2-13 x 1 1/2 and T-slot nuts. A customer-supplied bracket can be used for alternate toolsetter locations. Use 1/2-13 SHCS x 1" or M12 x 30 SHCS.

2. Mount table probe to probe mounting bracket. See probe alignment section for proper alignment instructions.



TOOL SETTING PROBE ALIGNMENT AND INDICATION

The OMI, spindle probe and table probe must be aligned properly for WIPS to function. In most cases, this is as simple as ensuring that the probe windows face the OMI when the probes are in operation. Alignment can be verified by following the probe activation procedure detailed in the operation section of this manual.

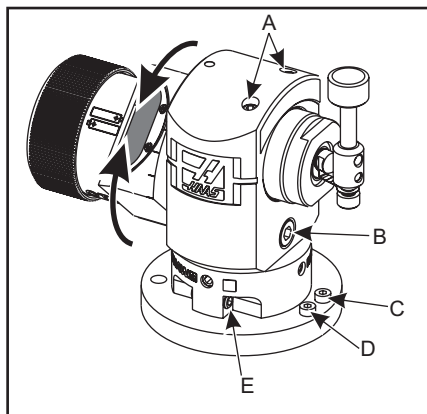

The probe window can be rotated in 15-degree (0 to 45 degrees in each direction) increments for alignment by removing the retaining bolt (B), rotating the probe window, and replacing and tightening the retaining bolt.

For accurate and proper function, the top surface of the stylus must be set level within 0.001" (0.02mm). To level the stylus:

1. Indicate the top surface of the probe stylus, checking level in the front to back and side to side directions.
2. To make front to back adjustments, loosen screw (C) and then use screw (D) to raise or lower the front of the stylus until it is level. Tighten screw (C) to lock front to back leveling.
3. Side to side adjustments are made with the two screws (A) at the top of the probe body. Alternately adjust these screws to rotate the stylus until side to side level is achieved, then tighten both screws equally.
4. Loosen screw (E) to allow the probe to rotate on its base, then tighten the screw to lock probe orientation.



Alignment to OMI

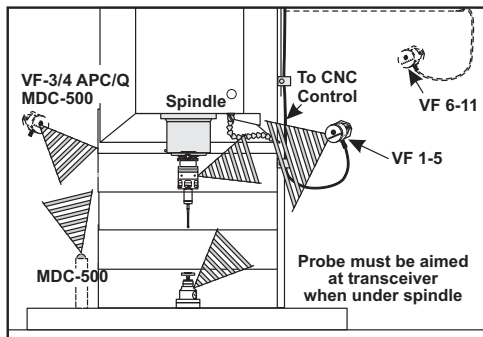

Vertical Mills

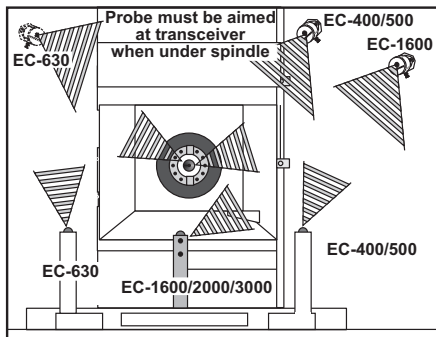

EC Machines

The diagrams above and below illustrate basic alignment between the spindle probe, the table probe, and the OMI for various machines. Use these as a guideline for proper aiming.

OMI alignment is especially critical in a GR machine, as the OMI must be able to communicate with the spindle probe at both ends of extensive Y travel, as well as Z travel from top to bottom.

ALIGNING THE WORK PROBE

To ensure accurate measurements, the work probe must be centered in relation to the spindle.

1. With the work probe assembly installed in the machine spindle, set a low-force dial indicator against stylus ball and rotate the work probe to check run-out. It should not exceed 0.0002”.
2. If adjustment is required, slightly loosen the two upper set screws (“B”). Slightly loosen the lower set of set screws (screw set “A”).

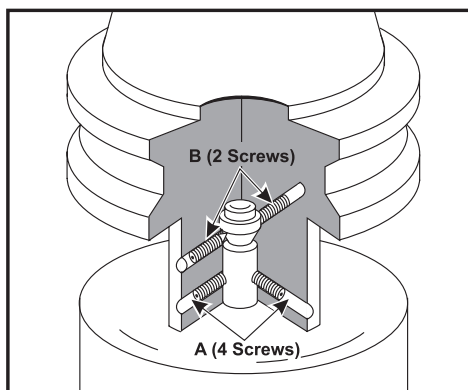



3. Progressively adjust the “A” screws in sequence and monitor alignment, loosening on one side and tightening on the other, bringing the probe into alignment.
4. When probe is aligned to within 0.0002”, tighten each “B” screw while tightening opposing “A” screw, each to no more than 0.5 ft-lb. Re-verify alignment and tighten the remaining “A” screws.



I/O Board Probe Interface Versions

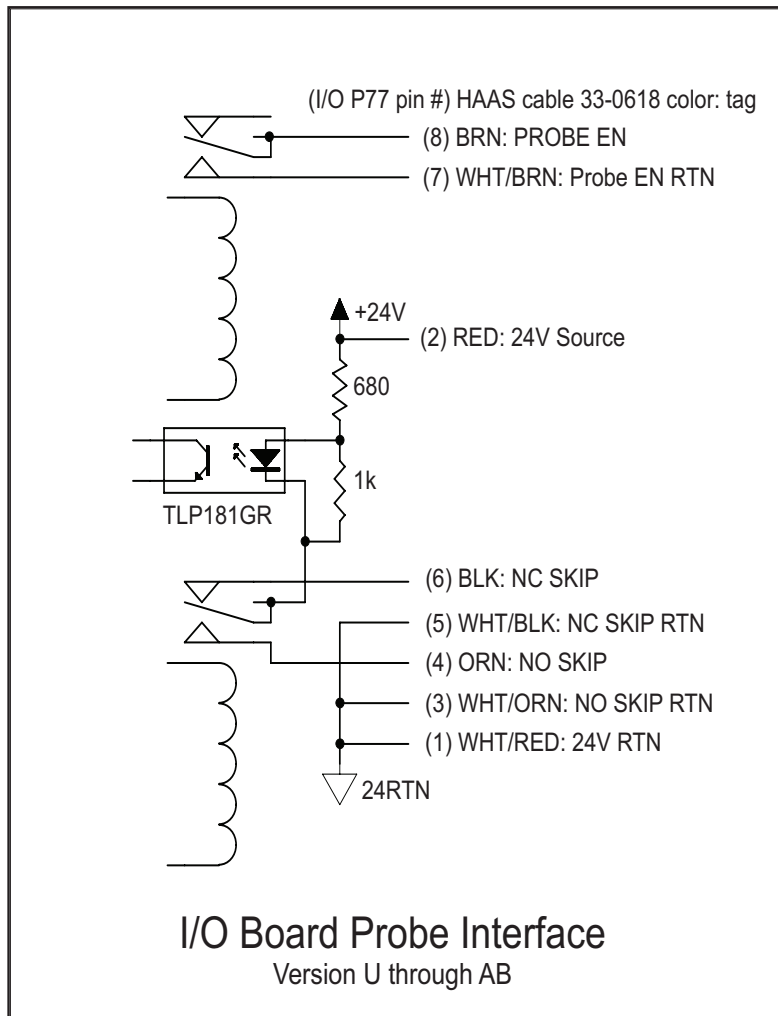

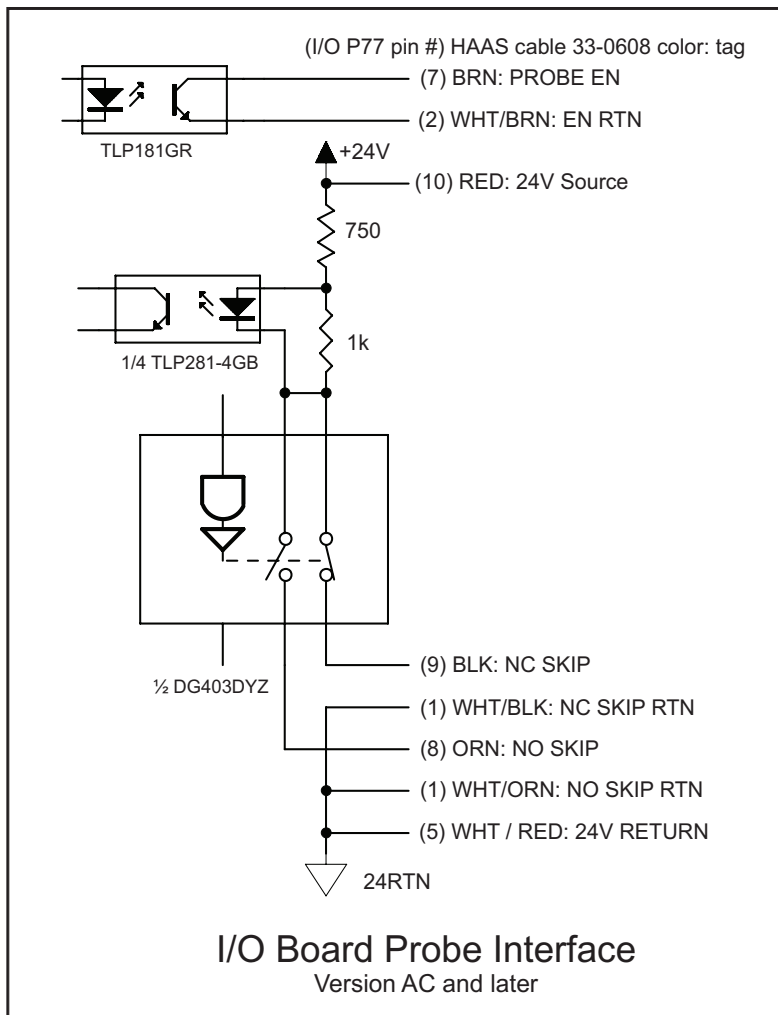

Warning

Power down the machine before any work is done.

Upper Entry Into Control Cabinet: Route the cable conduit into the J-box at the top of the control cabinet. Pull the cable down through the center vertical wire channel and route to the E83T unit. Connect the OMI cable to the 6-pin plug on the E83T.

Lower Entry Into Control Cabinet: Route the cable conduit to the bottom of the control cabinet. Secure the conduit jacket to the outside of the control cabinet with a cable tie. Route the cable up through the center vertical wire channel and connect to the 6-pin plug on the E83T plug.



Side Entry into Control Cabinet: Use the vacant hole in the side of the cabinet nearest to the wire channel above the I/O PCB. Slide the cover plate (25-1391) over the conduit and secure to the cabinet using two PPHS 8-32 x 3/8" and two 8-32 hex nuts with lock washers. Fasten the end of the conduit to the cover plate with the conduit nut. Route the OMI cable along the center horizontal wire channel and connect to the 15-pin plug on the E83T unit.

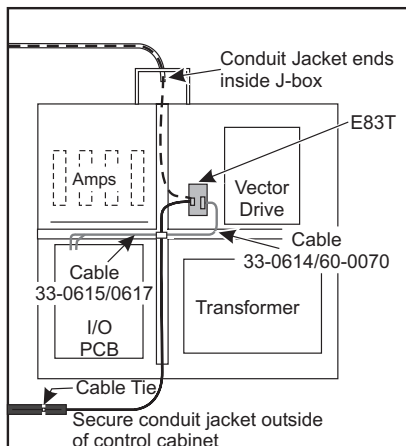

Upper / Lower entry into Control Cabinet

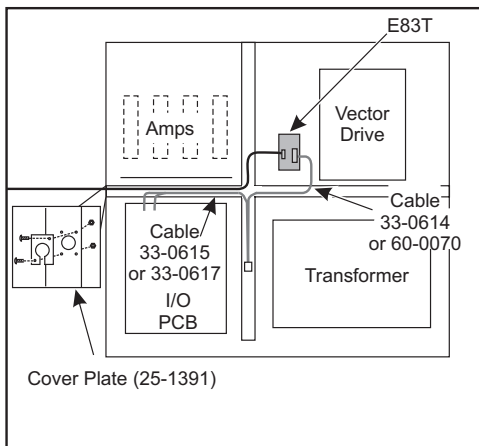

Side Entry Connection

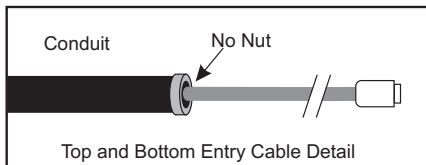

Top and Bottom Entry Cable Detail

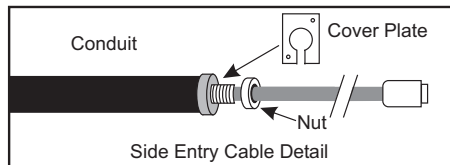

Side Entry Cable Detail

CABLE CONNECTIONS

Renishaw Electrical Installation - up to I/O Version AB

1. Route the OMI cable through the top or bottom of the control cabinet as shown, depending on the installation performed.
2. Join the OMI cable and 33-0615 cable plugs. Plug the Haas probe cable 33-0615 into P77 on the I/O board. Plug the jumper from the probe cable into M22.

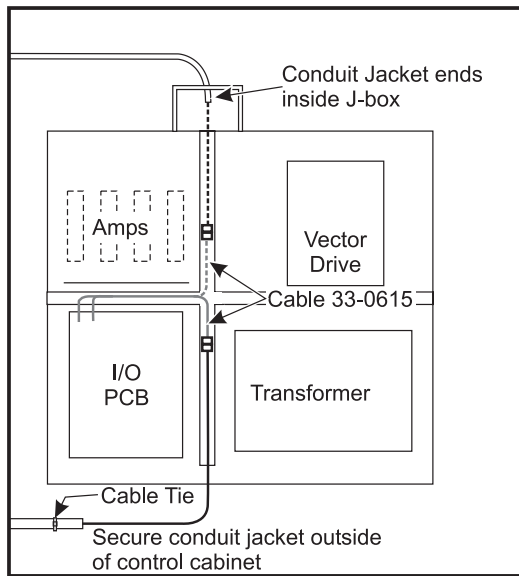

Upper / Lower entry into Control Cabinet

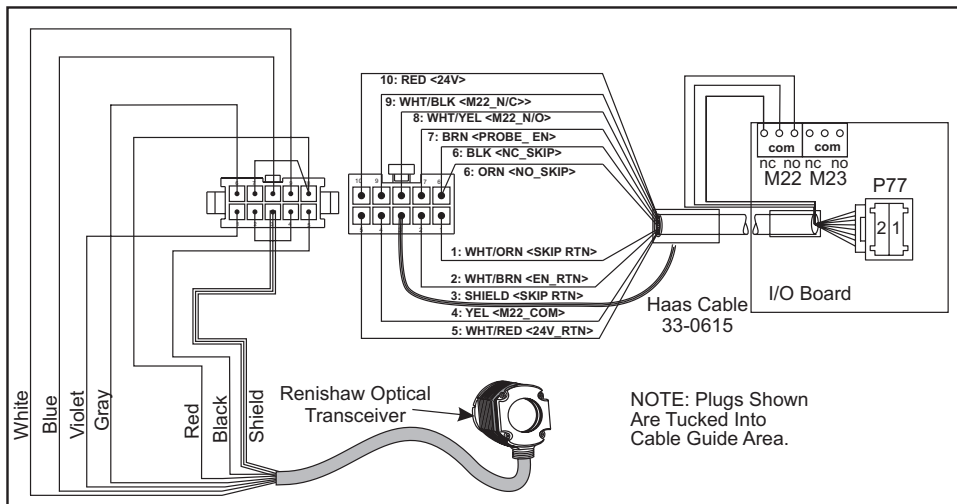

Renishaw Electrical Installation I/O Version AC and later.

1. Route the OMI cable through the top or bottom of the control cabinet as shown, depending on the installation performed.
2. Join the OMI cable and 33-0616 cable plugs. Plug the Haas probe cable 33-0616 into P77 on the I/O board.

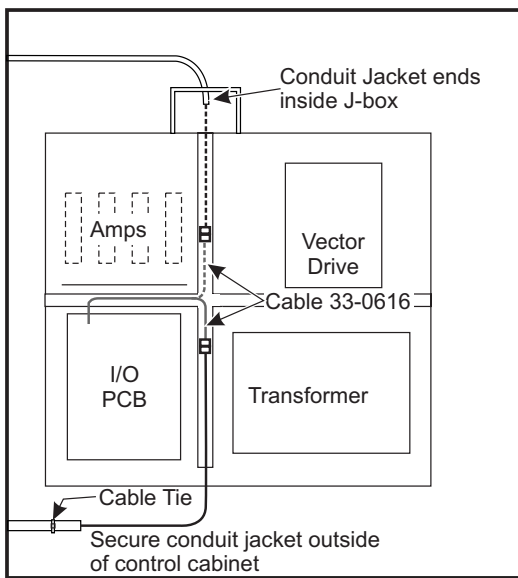

Upper / Lower entry into Control Cabinet

